



Certificates



XI'AN YUNYI INSTRUMENT COMPANY LIMITED



- 1. Pressure Transmitter
- 2. Pressure Gauge
- 3. Pressure Calibrator
- 4. Dead Weight Tester
- 5. Level Transmitter
- 6. Flow Transmitter
- 7. Temperature Transmitter
- 8. Density Meter



GENERAL INFORMATION

This manual will assist you in installing, using and maintaining Vortex Flowmeter. It is our responsibility to make sure that all operators have access to adequate instructions about safe operating and maintenance procedure.



Warning

For your safety, review the major warnings and cautions below before operating your equipment.

1. Use only fluids that are compatible with the housing material and wetted components of your Vortex
2. When handling hazardous liquids, always exercise appropriate safety precautions.
3. When measuring flammable liquids, observe precautions against fire or explosion.
4. When working in hazardous environments, always exercise appropriate safety precautions
5. Handle the sensor carefully. Even small scratches or nicks can affect accuracy.
6. For best results calibrate the meter at least 1 time per year.
7. Do not purge the flow meter with compressed air.
8. During Vortex removal, liquid may spill. Follow the manufacturer's safety precautions for clean up of minor spills

Application

vortex flow meter is a speed flow meter, widely used in petroleum, chemical, power, light industry, power, heating and other industries.

Operation Principle

YFV series Vortex flow meters are designed for measuring the volume/mass flow of liquids, gases and steam based on Karman vortex principle.

Adopting advanced differential algorithm along with measurement of isolation, shielding and wave filtering, YFV series vortex flow meters have the advantages of immunity on vibration and noise. Meanwhile, the liabilities of YFV series vortex flow meters are well guaranteed by unique sensor packaging technology.

Product Structure

The basic structure of the vortex flow meter is shown in Diagram 1. It is mainly composed of body, probe, vortex generator, meter rod, condenser pipe and converter.

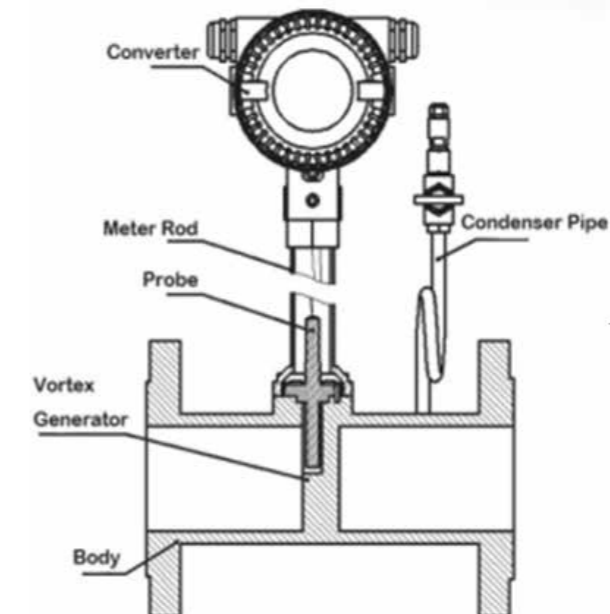

Diagram 1.

TECHNICAL DATA

Measuring System

Application range	(1)Gas;(2) Liquid;(3) Steam
Measured value	
Primary Measured Valuer	Flow Rate
Secondary Measured Valuep	Volume flow;(Pressure and Temperature is available for modelwith compensation)

Reference Condition	Flow conditions similar to EN 29104
	Medium: Water/ Gas / Steam
	Electrical conductivity:≥ 300 μS/cm
	Temperature:+10...+30°C/+50...+86°F
	Inlet section:≥10 DN
	Operating pressure:1 bar / 14.5 psig
Accuracy	For Liquid: 1.0% of rate
	For gas and steam: 1.5% of rate

Design

Features	
Modular Construction	The measurement system consists of a flow sensor and a signalconverter, It is available as compact and as separate version.
Converter Function	N Type:24V DC; Pulse output; No display: Ex
	A Type:24V DC;4-20mA output; No display; Ex
	V Type:24V DC;4-20mA/Pulse output (V type is only for Gas/ Steam application): Digital display: Ex
	Notice: 1) Modbus RS485 is optionalfor C、 V、 D series2)Dual power(24V DC+ Battery) is optional for C、 V、 Dseries
Connection	Flange:DN15-DN300
	Wafer: DN15-DN300
Measurement Ratio	Standard - 10:1

Operating Condition

Temperature	
Process Temperature	T1 Level:-20...+70 °C
	T2 Level:-20...+250 °C
	T3 Level: -20...+350°C
Ambient Temperature (all versions)	Standard (with aluminum converter housing)
	-10...+55°C
Storage Temperature	-20...+70°C
Pressure	
EN 1092-1	DN200...DN300:PN10
	DN100...DN200:PN 16
	DN15...DN80: PN 25
	Other pressures on request
Measurement Ratio	1/2" ..8": 150 lb RF
	Other pressures on request
JIS	1/2" ..8": 10 K;20 K;etc
	Other pressures on request

Installation Condition

Installation	Make sure that flow sensor is always fully filled
	For detailed information see chapter"Cautions 4for Installation"
Flow Direction	Forward
	Arrow on flow sensor indicates flow direction
Inlet Run	≥10DN
Outlet Run	≥5 DN

Materials

Sensor Housing	SS304
	Other materials on request
	Flange Connection:SS304
	Wafer Connection Mating(Flange: Carbon Steel)
Converter Housing	Standard: polyurethane coated die-cast aluminum

Process Connection

Flange	
EN 1092-1	DN15...300in PN 6...25
ASME	1/2"...12"in 150 lb RF
JIS	1/2"...12"in 10...20K
Design of gasket surface	RF
	Other sizes or pressure ratings on request
Wafer	DN15...DN300

Measurable Flow Range

Flange		Saturated steam Kgs/h
15	1/2"	11~130
20	3/4"	20 ~230
25	1"	130~360
40	1-1/2"	180~1980
50	2"	205~2960
65	2-1/2"	251~4580
80	3"	404~6600
100	4"	560~10900
125	5"	700~15700
150	6"	1220~23300
200	8"	1750~41750
250	10"	2570~59100
300	12"	3380~91000

Note: The flow range above is for reference only. Consult the factory if you have special requirement. Refer to the nameplate or certificate for actual flow range.

CAUTIONS FOR INSTALLATION

Mounting Position

☆ Pipes must be fully filled with liquids. It is essential that pipes remain fully filled at all times, otherwise flow rate indications may be affected and measurement errors may be caused.

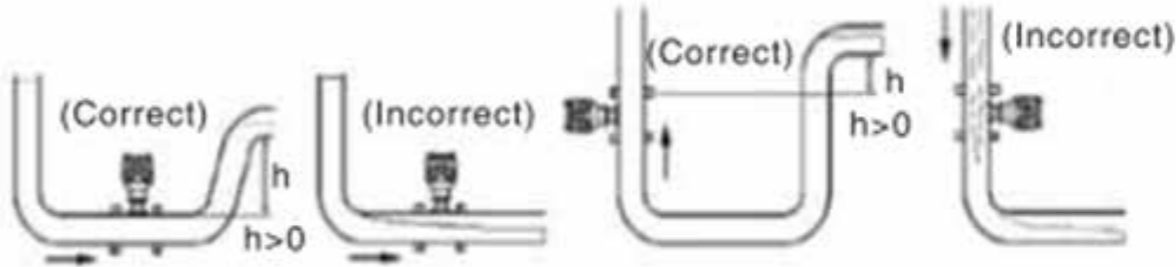

Mounting Positions

★ Avoid Air Bubbles. If air bubbles enter a measurement pipe, flow rate indications may be affected and measurement errors may be caused.

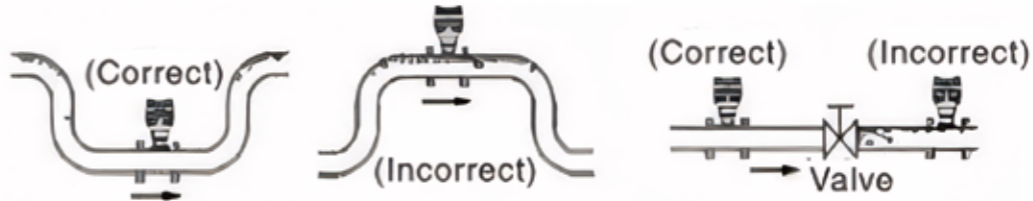

Avoiding Air Bubbles

- ★ Avoid all pipe locations where the flow is pulsating, such as in the outlet side of piston or diaphragm pumps
- ★ Avoid locations near equipment producing electrical interference such as electric motors, transformers, variable frequency, etc.
- ★ Install the meter with enough room for future access for maintenance purposes

⚠ Warning: Precaution for direct sunshine and rain when the meter is installed outside.

Required Length of Straight Runs

Flow altering device such as elbows, valves and reducers can affect accuracy. check diagram 2 for typical flow meter system installation

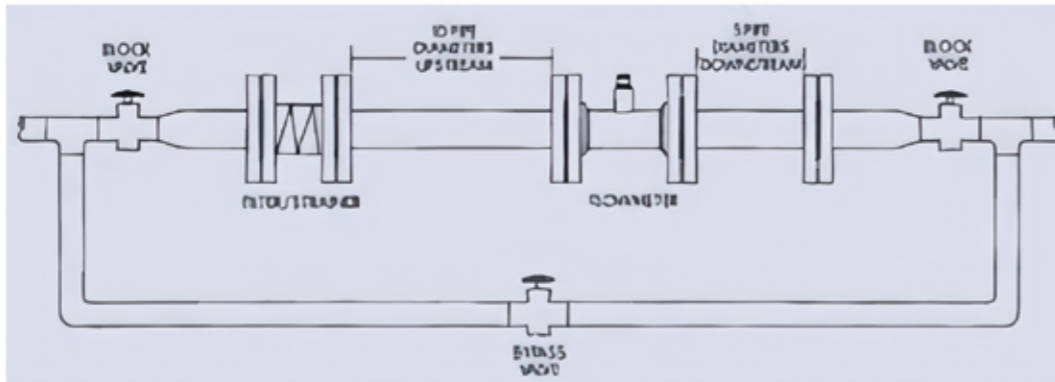
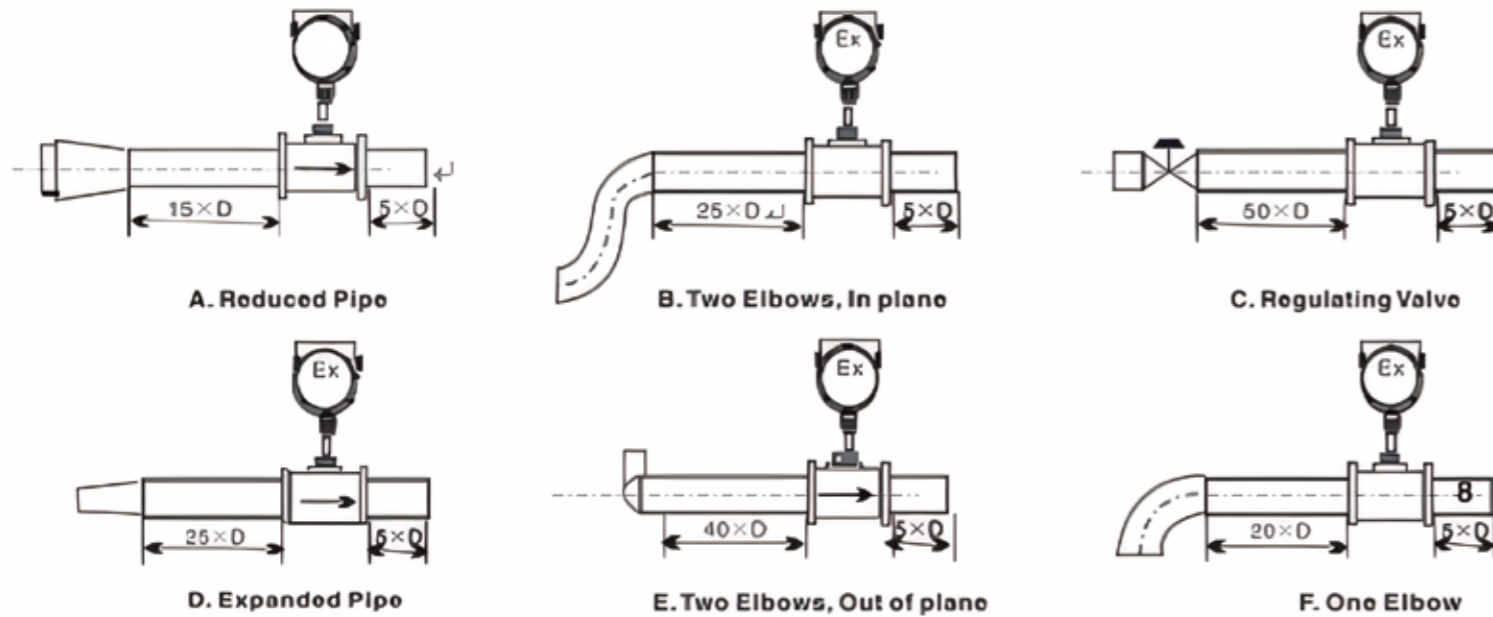

Diagram 2 General Flow Meter System Installation



The recommended guidelines are given to enhance accuracy and maximize performance.

Distance given here are minimum requirements; Double them for desired straight pipe lengths.

☆ Upstream: allow a minimum straight pipe length at least 10 D the internal diameter of the pipe. For example, with the 50mm pipe, there should be 500mm of straight pipe immediately upstream. Desired upstream straight pipe length is 1000mm.

☆ Downstream: allow a minimum straight pipe length at least 5 D the internal diameter of the pipe, For example, with the 50mm pipe, there should be 250mm of straight pipe immediately downstream. Desired downstream straight pipe length is 500mm.

Anti-Cavitation

Cavitation can be caused by entrained air, An amount higher than about 100 mg/l of entrained air or gas can produce error. In addition, cavitation can be caused by too little backpressure on the flow meter. For our Vortex flow meters, you should provide a backpressure (downstream pressure) of at least 1.25 times the vapor pressure, plus 2 times the pressure drop through the flow meter. See formula 14

Formula 1: $P_b \geq 1.25 \times P_v + 2 \times (P_{in} - P_{out})$

in formula 1: (P_b: Back pressure; P_v: Vapor Pressure; P_{in}: Inlet Pressure; P_{out}: Outlet Pressure) Create backpressure by installing a control valve on the downstream side of the meter at the proper distance detailed above.

⚠ Special Notice

When the fluid is liquid, to ensure accurate measurement, drain all air from the system* before use. When the meter contains removable coverplates. Leave the coverplate installed unless accessory modules specify removal. Don't remove the coverplates when the meter is powered, or electrical shock and explosion hazard can be caused.

CONNECTIONS

Flange Connection

Installation	Make sure that flow sensor is always fully filled
	For detailed information see chapter "Cautions for Installation"
Flow direction	Forward
	Arrow on flow sensor indicates flow direction.
Inlet run	≥10DN
Outlet run	≥5DN

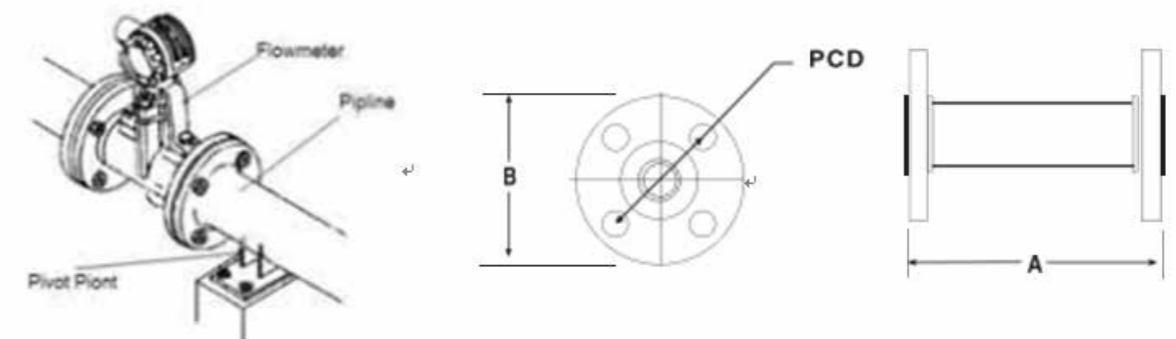

DIN PN16 Flange Meter Dimensions

Size Code		A	DIN Flange Pressure Rating	Flange Diameter (B)	Bolt Hole Diameter	Bolt Circle Diameter (PCD)	Bolt Hole Quantity
(Inch)	(mm)	(mm)	Mpa	(mm)	(mm)	(mm)	
1/2"	15	180	1.6	95	14	65	4
3/4"	20	180	1.6	105	14	75	4
1"	25	180	1.6	115	14	85	4
1-1/4"	32	180	1.6	140	18	100	4
1-1/2"	40	180	1.6	150	18	110	4
2"	50	180	1.6	165	18	125	4
2-1/2"	65	200	1.6	185	18	145	4
3"	80	200	1.6	200	18	160	8
4"	100	200	1.6	220	18	180	8
5"	125	220	1.6	250	18	210	8
6"	150	220	1.6	285	22	240	8
8"	200	220	1.6	340	22	295	12
10"	250	250	1.6	405	26	355	12
12"	300	300	1.6	460	26	410	12

Note: For model with temperature and pressure compensation, the flowmeter length should be increased 50mm compared to the value (A) in table above.

Wafer Connection

Installation	Make sure that flow sensor is always fully filled
	For detailed information see chapter "Cautions for Installation"
Flow direction	Forward
	Arrow on flow sensor indicates flow direction
Inlet Run	≥10DN
Outlet Run	≥5 DN

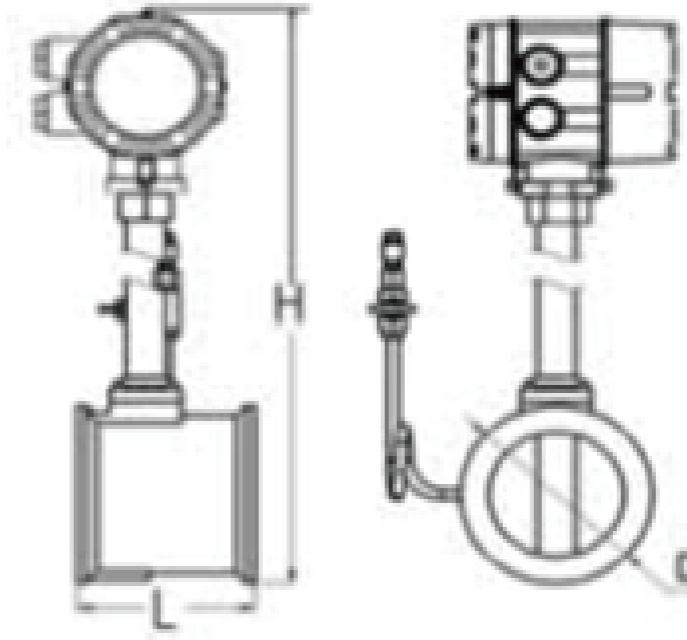

Diameter mm	L mm	L0 mm	D mm	H mm	Pipe Specification
15	66	94	66	425	o18*1.5
20	66	94	66	425	o25*2.5
25	66	94	66	425	o32*3.5
32	66	94	66	425	o39*3.5
40	80	112	77	425	o49*4.5
50	80	120	89	435	o59*4.5
65	93	137	102	445	o74*4.5
80	100	144	113	460	o89*4.5
100	125	173	135	485	o109*4.5
125	145	197	158	515	o134*4.5
150	165	217	181	545	o159*4.5
200	196	252	248	600	o219*11
250	120	166	300	650	o273*11
300	135	185	350	700	o325*12

CAUTIONS FOR INSTALLATION

Warning: Electrical Hazard Disconnect power before beginning wiring

HGVF-N: Pulse Output, Explosion Proof Model

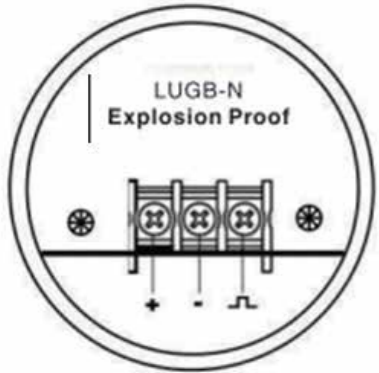

Terminal Wiring

Terminal Symbols	Description
+	Power Supply:"24V+"
-	GND
	Pulse Outputp

Terminal Configuration

HGVF-A:Two-wire 4-20mA Output, No Local Display

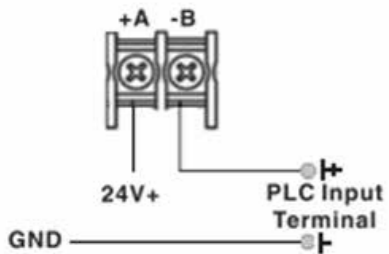

Terminal Symbols	Descriptionp
+A	Power Supply: 24V+
B	Current Output

Terminal Wiring

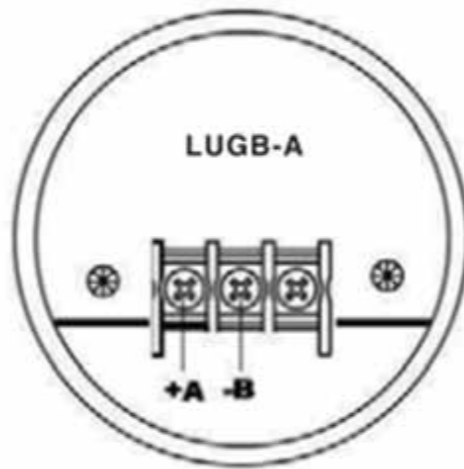

Terminal Configuration

HGVF-VLocalDisplay

Terminal Board of V Type

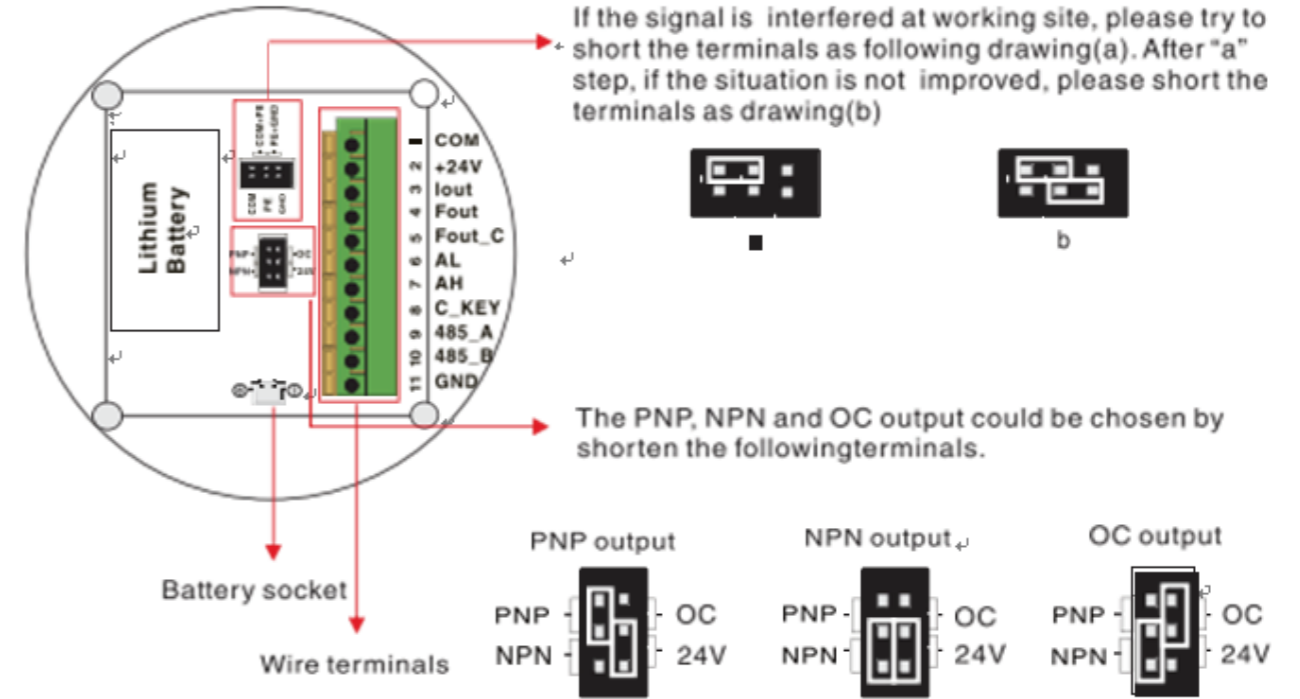

Wiring Descriptionu

(1)2 wire 4-20mA output

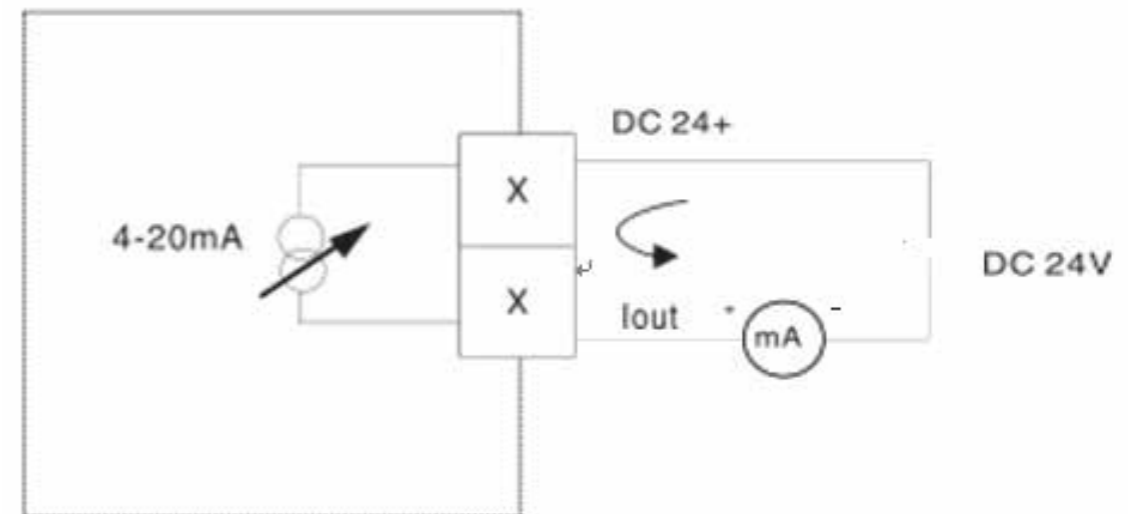

(2) 3 wire 4-20mA output

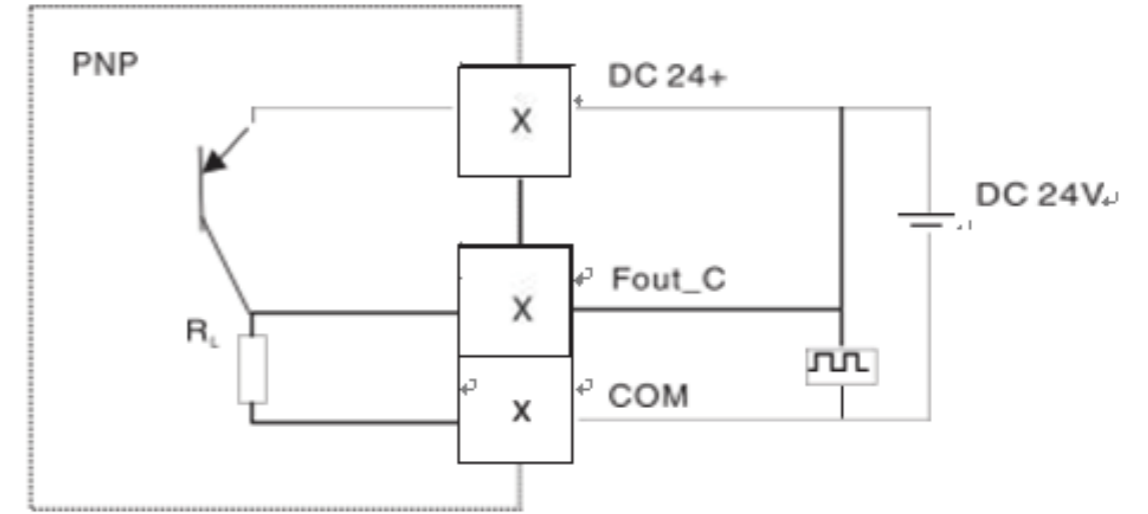
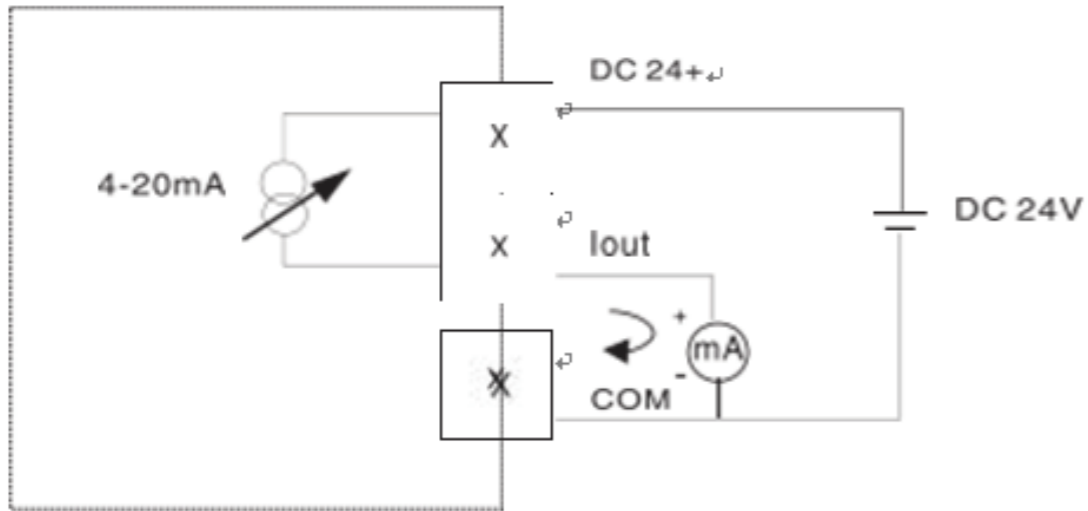

(3) Pulse Output/ Scaled Pulse Output

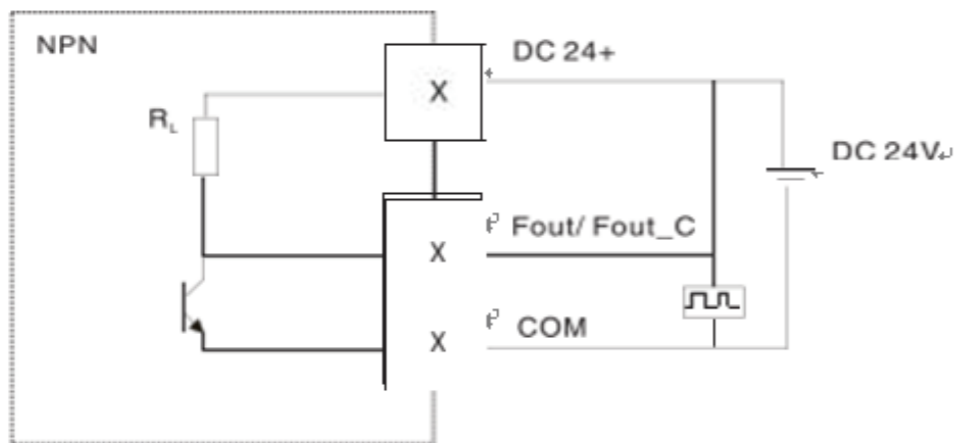
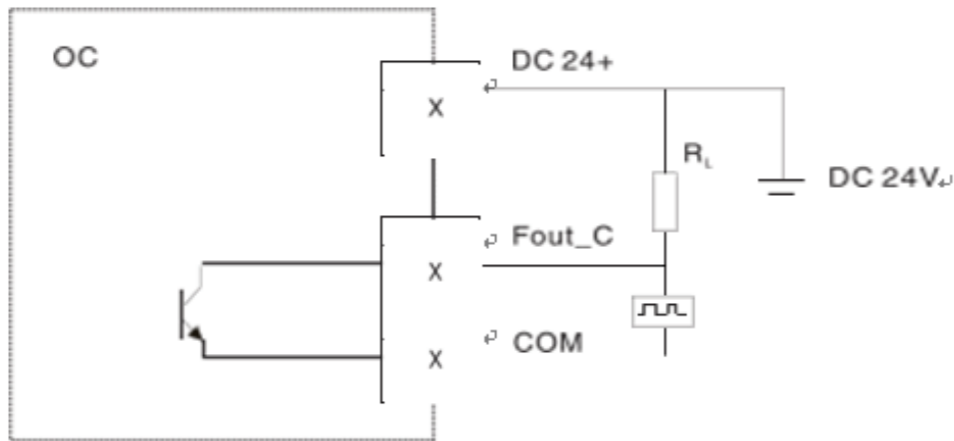

(4) RS485 Communicationg

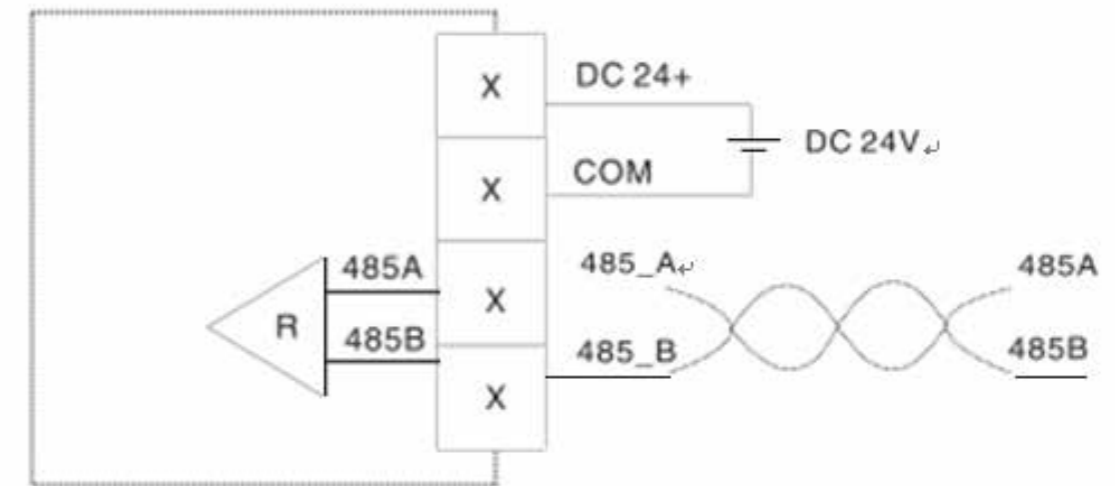

HGVF-D. Local Display

Wire Terminal Description

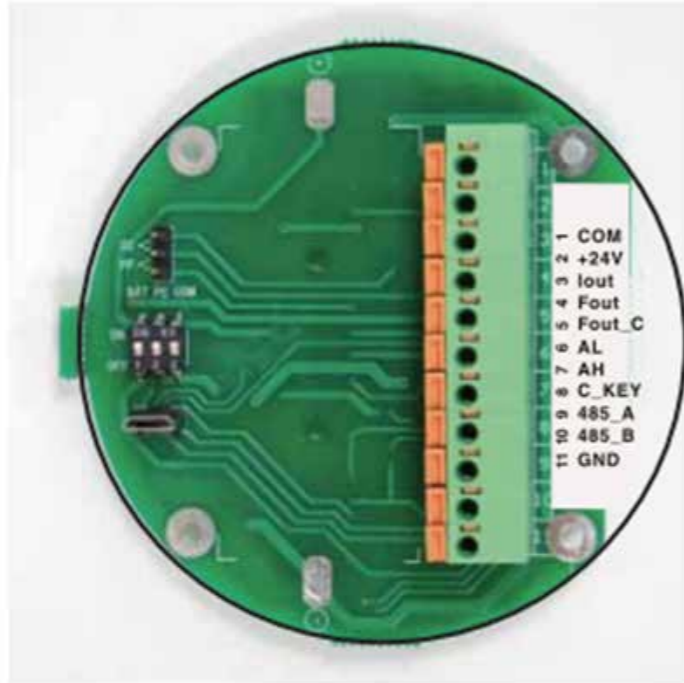

Terminal No	Terminal Symbols	Terminal Description	Notep
1	CoM	24VDC-	
2	DC24+	24VDC+	
3	lout	4-20mA Current Output	
4	FoUT	Pulse outputp	oNLY FoR CAL1BRAT1oN
5	FoUT	Frequency or scaled pulse output	
6	AL	Al _mm for low levele	
7	AH	Al _mm for low levele	
8	C KEY	Connebt to extern_l reset autton termin_ls	Pressing the extern_l autton for over 5 sebond
9	458 A	RS485A	
10	485 B	RS485B	
11	GND	Grounding termin_l for the extern_l reset	Use with C KEY termin_l

2 wire 4-20mA output

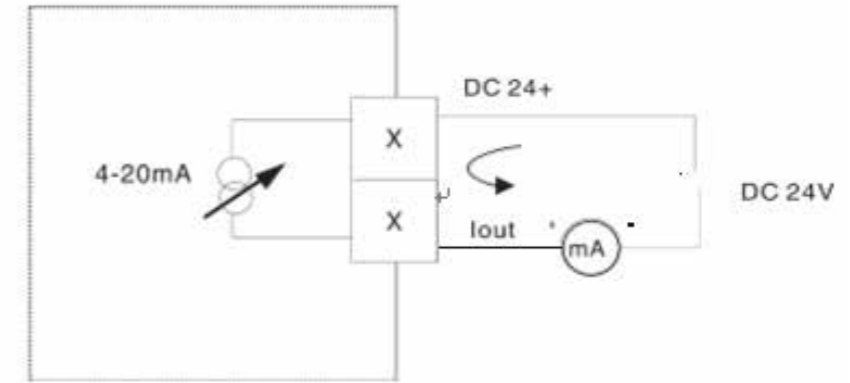

2 wire 4 .20mA burrent output wiring di_gr_m

3 wire 4 . 2 0 mA current output wiring instructions.

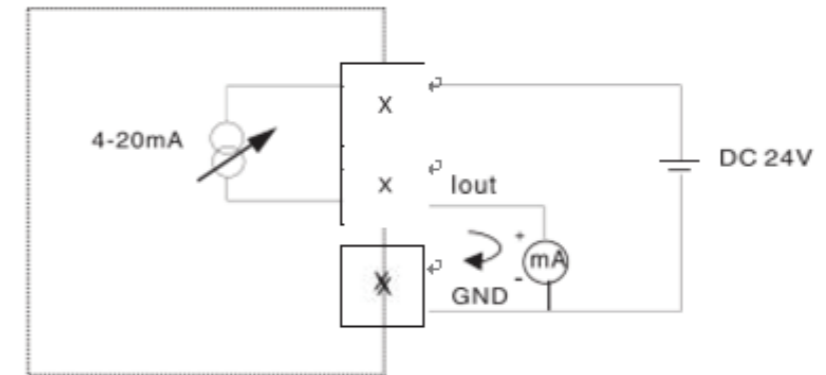

3 wire 4 .20mA burrent output wiring di_gr_m

Pulse output wiring instructions

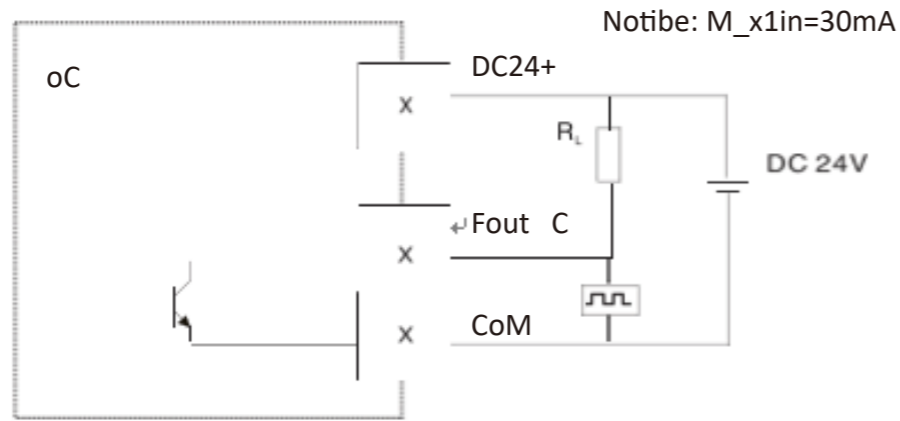

oC Pulse output wiring di_gr_m

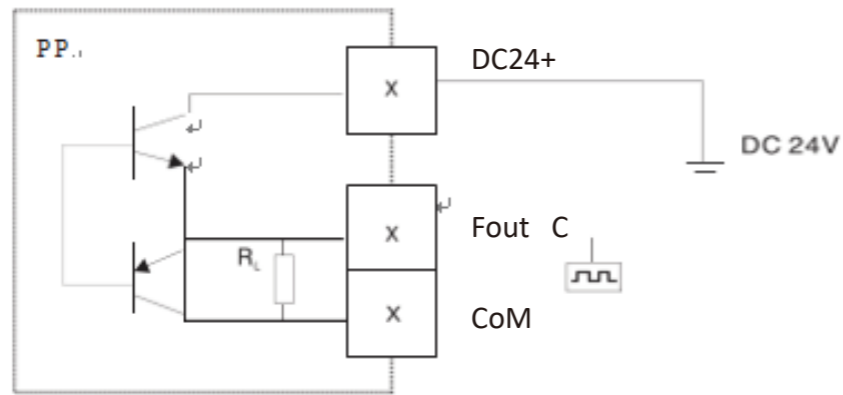

PP Pulse output wiring di_gr_m

RS485 communication wiring instruction

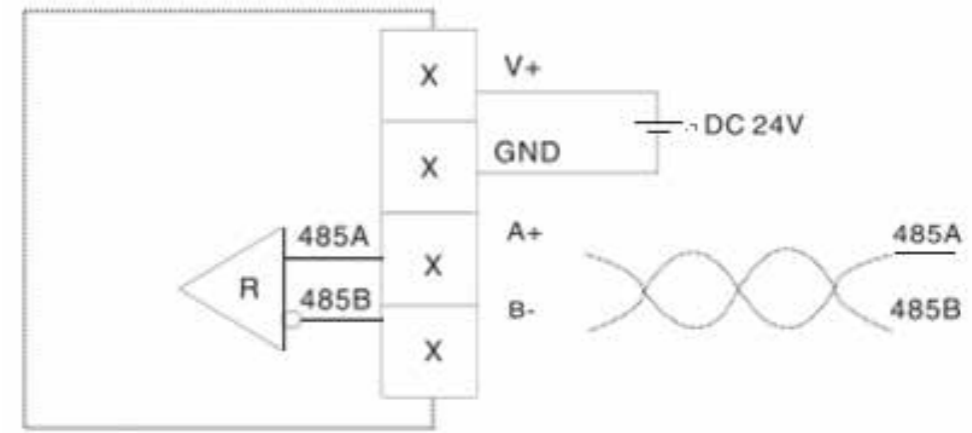

Notice:

- 1.The requirement for the pulse output _s following:
- 2.High level _mplitude > 2.2 V; Low level mplitude < 0.8 V :Pulse frequenby < 3000 Hz
- 3.The lod resistor < 500 o.
- 4.The protobolis MoDBUS . RTU

Pulse output.



Push . pull output

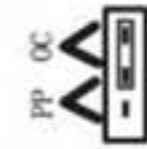

oC output

PROGRAMMING AND SETUP

All flowmeters are tested and calibrated prior before left the factory, and the keyK-factor is provided on the calibration certificate. Keep the calibration certificate wellto avoid the loss of K.factor

HGVF-N+ No display; Pulse output

Customer should set the correct K-factor into PLC or flow totalizer in order to get the correctflow rate.

HGVF-A

Only perform the Zero Point Calibration where it's necessary.

Zero Point Calibration

- (1) Shut off the valve where the flowmeter is installed, ensure there is no flow rate in pipe.
- (2) Put high accuracy amperometer into the circuit loop as series connection.
- (3) Adjust the potentiometer W502 to make sure the display on amperometer is 4mA.

Full Scale Calibration: + It's ONLY available for factory: Return the flowmeter to factory for full scale calibration where is applicable.

HGVF-V+: Local Display; 4-20mA/ Pulse Output

Note: all menus are present in all signal converter versions, but some parameter settings are ONLY valid for specified models

Display and Key Button

Five Sections on Display Screen.

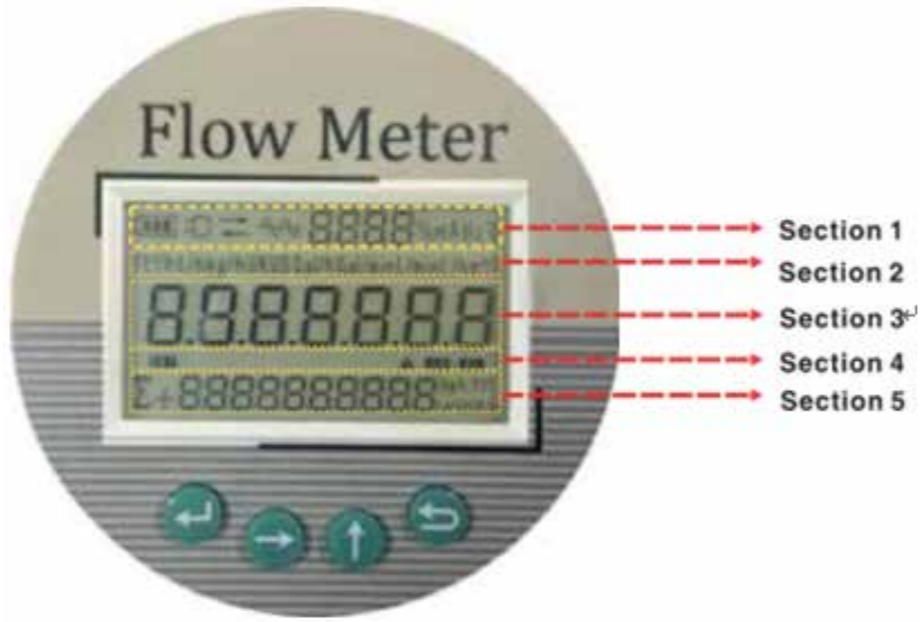

- Section 1: Functional region which consists of battery situation, communication current, frequency, flow percentage (Temperature could be available on request)
- Section 2: Units section which consists of 10 units: m³/h, L/h, L/min, US Gal/min, UK Gal/min, US Gah, UK Ga/h, kg/h, th, ft³/h
- Section 3: Flow rate (7 digital figure upper line)
- Section 4: Alarm sign which consists of SET prompt and alarm prompt
- Section 5: Total flow (11 digital figure lower line) with two decimal places

Buttons

Interface buttons (four keys)

Buttons		
Interface Buttons		Turn page/Confirm
		Move cursor
		Increase number/ Turn page
		Exit

Operation

Menu				
Main menu	Go to sub-menu	x	x	x
Sub-menu	Go to password menu	x	x	Back to main menu
Password Menu	a. False or No password will go to the next menu b. Correct password: The parameter is settable.	Move cursor	Set parameter	Back to main menu
Settable Menu	Set/Saver	Move cursor	a. Settable status: increase number or choose number: b. Un-settable status: Turn to previous menu	Cancel the setting and back to main menu
Un-settable Menu	Turn to next menu	x	Turn to previous menu	Back to main menu

Parameter Set
Password

Typar	Passwords	Note
User password	1234	it will display "1234"
Engineer password;	1010	it will display "1010"
Total flow reset	5555	it will display "5555"
Storage factory defaulted;	5678	it will display "5678"
Reload factory defaultsp	1111	it will display "1111"
Total flow set	9999	it will display "9999"
Fixed current output	0101	it will display "0101"

Note: It will display "0000" before input password. If the password is incorrect, it will go to P1 menu automatically under un-settable status.

Password;	coder	Functione	Parameter.	Notep
0000	Main menu	Normal display;	Display working condition, flowrate, total flow	
		Frequencydisplay	The second line is original frequency The third line is corrected frequency/signal intensity	Up key can be used to switch
	Passwords	Password input	4 digital figurep	

Password.	Code	Function	Parameter		Note
1234	1P	Unit	0-.m3/h	5. US Gal/h	Other parameters setting the variables associated with units will be related automatically, according to the units of P1 to calculate. such as total flow, flow rate. scaled pulse and so on.
			1. L/h	6 .UK Gal/h	
			2. L/minc	7. kg/p	
			3.US Gal/ming	8. t/p	
			4.UK Gal/min	9. f/h	
	P2	Damping Time	01-99s		To slow flow changes and prevent jump
	P3	Maximum Flow Rate	Maximum Flow settings. the unit corresponds to the flow.		Exceed the maximum flow, showing the imum flow
	P4	Minimum Flow Rate	Minimum flow settings, the unit, corresponds to the flow.		When the flow rate is lower than minimum flow rate. the flow rate will show "O"
	P5	Max Frequency . Output	The upper limit setting of measuring frequency		When it exceeds the upper limit, it will display max value
	P6	Relative Density	Absolute density of medium. Unit: kg/m3		Use quality units It will be used in the calculation
p7	Crequencodet	0- Shut down and keep low level		This parameter just aims at Fout_c port operation Fout is not restricted by this menu	
		1- Negative pulse correction frequency			
		2- Positive pulse correction frequency			
		3- Negative scaled pulser 4- Positive scaled pulsep			
P8	Scaled-pulse Output	0.001,0.01,0.1,1,10,100,1000		Unit is in accord with P1 menu	
P9	Pulse Width.	1 - 2000 ms		The width setting of scaled pulse	
P10	Communication	0:RS485 1: Hartp		1: It' s available to current output with, HART version	

Password.	Code	Function	Parameter		Note	
1234	P11	Communication Parameter	RS485	Address	0-255	No verify- Oddfy Even verify
				Baud Rate	1200,2400, 4800,9600, 19200	
				Verification	N, O, E	
				Data Length	7,8	
				Stop BitsLength	1,2	
	P12	High LimitAlarm	Switch Settings	Address	0-255	
				Yes	On	
			no	Close		
			Alarm Level	HIGH	High Level	
				LOW	Low Level	
			Alarm Value	0-100%	Alarm Value	
			P13	Low Limit Alarm	Switch Settings	Yes
	no	Close				
	Alarm Level	HIGH			High Level	
		LOW			Low Level	
	Alarm Value	0-100%			Alarm Value setting corresponding to flowprate	
	P14	Backlight	Working Mode	0- Off mode	2:2wire power supplyshuts down;3-wire power supply normal-lyopens: battery powered button turns off thedelay.Long press Esckey to switch 0 modeand 1 mode, searchingnetwork.	
				1- Automaticmode		
				2-On mode		
			Brightness Setting	0-30%		
				1-70%		
2-100%						

Password	Code	Function	Parameter	Note	
9999	P15	Total Flow	Modifying total flow value		
1010	P16 - P23	Linearizationof the Flowcurve	The first line is correctedfrequency, the second line is coefficient error P16-P23F1-F8: eight coefficientmodification Wn=Kn/KP(n:1-8)3	F1 must be started. andF2-F8 are started in properorder.If the factor is 0 thispoint and followingcorrected points should bestopped.	
	P24	CorrectCoefficient	The first line shows thecorrected frequen-cy;the secondline shows the meter coeffi-cient.and the unit of coefficient ispulse/m3	It could be any of thecoefficient (Kn) fromF1F8 or Max one orAverage.	
	P25	Diameter	Selecting the diameter of body and sensor	Unit: mm	
	P26	Medium	0 - Gas 1- Liquid	the type selection of.measured fluid	
	P27	Min VibrationStrength	The collection value in secondline in the process oflearning can be manually changed	P27-P30 Selflearnin-gantivibration : Continueto press the up button 5secondsand the countdown is completed-in 60 seconds.Notice: this operation isprohibited when there isflow rate.	
	P28	Max Vibration Strength	The third line shows the strength of the current signal.		
	P29	Min Vibration Frequency	The collection value in secondline in the process oflearning +can be manually changed.		
	P30	Max Vibration Frequency	The third line shows the frequency of the current signal.		
	P31	Min Working Frequency	Lowest acceptable signal frequencyThe third line shows the currentsignal frequency.	Meter working area settingInstruction:in the pipelineof having slight vibration.it can sianificantly enhance the capacity ofresisting disturban-cethrough the three screenparameter settings andstrict limit of effectiverange.	
	P32	Max Working Frequency	Highest acceptable signal frequency The third line shows the currentsianalfrequency.		
	P33	Min Signal Intensity	Lowest acceptable signalfrequencyThe third line shows the currentsignal intensity.		
	0101	Fixed Current Output		Input Range:0-99 Effective Value: 4-20Unit: mA	The utility model is suitablefor the current loop test,the svstem adjustment andthe instrument calibration.

Password	Code	Function	Parameter	Note
5555		Total flowreset		
5678		Storage factory Pdefaulted	Save factory defaults	Backup current settings
1111		Reload factory defaults	Reload factory defaults	Restore factory parameters from backup area

HGVF-Dwith Temperature and Pressure Compensation

The Basic Structure of Converter

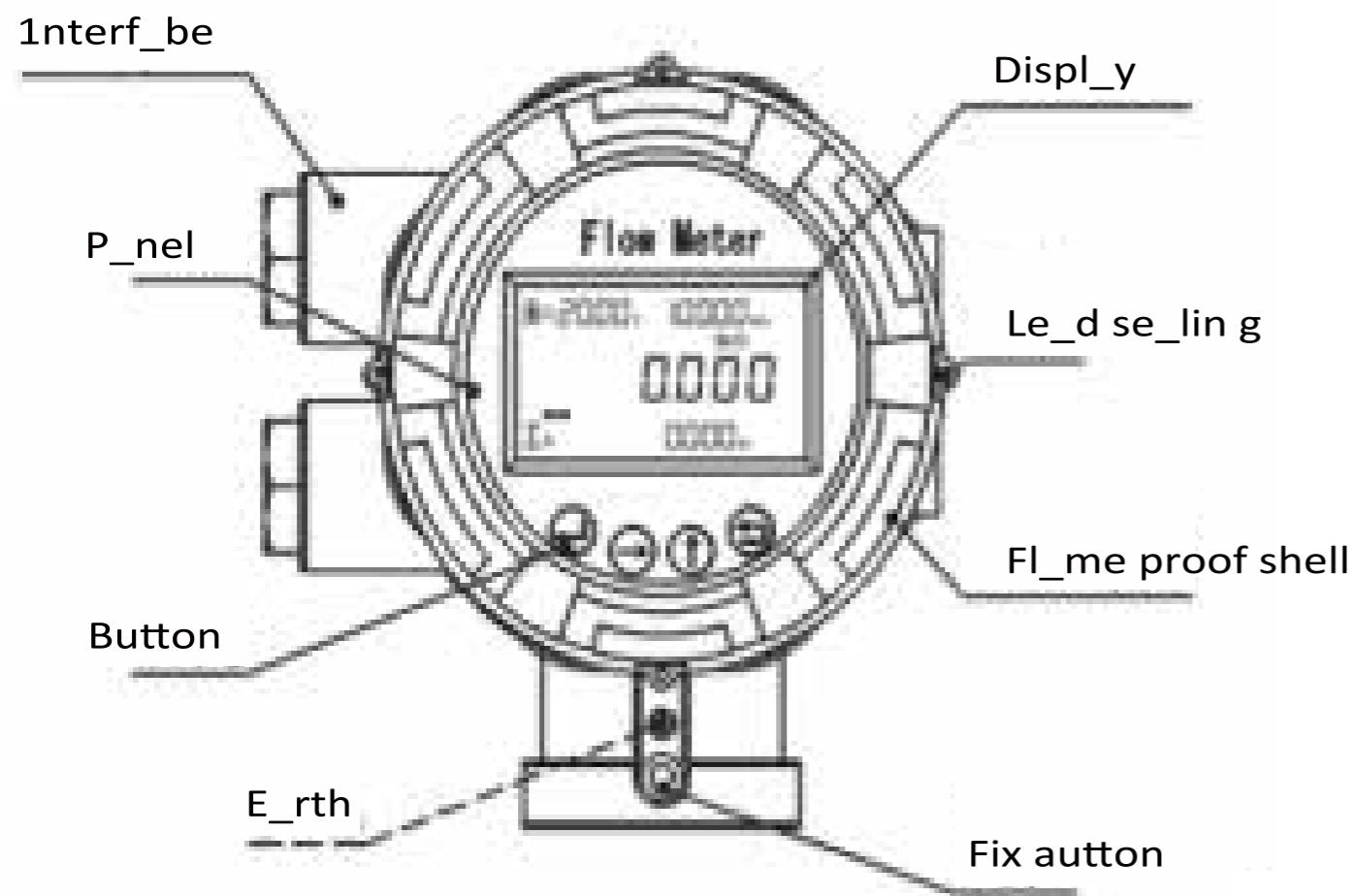

Diagram 6-1 The basic structure of converter

Button Description

	Buttons	
Interface Buttons		Turn page/Confirm
		Move cursorp
		Increase number/ Turn page
		Exit

Extern_l autton

1.Press short time The first short time press will displ_y the bommunib_tion p_r_meters _nd the soft-w_re version numeer.
 2 . Press long time when extern_l ble_r funbtion set to "0", it will shut down the ble_r funbtion . when extern_l ble_r funbtion set to "1", the first time long press(over 3s), the v_lue will reset . 1f long press _g_in _fter the first long press menu, the tot_l go to zero, _nd return to the m_in menu; if no oper_tion for 100s, it will return to m_in menu _utom_tib_lly. when extern_l ble_r funbtion set to "2", the tot_l now will ae reset _fter press 3 sebond

Measuring Mode Description

1.Press short time The first short time press will displ_y the bommunib_tion p_r_meters _nd the soft-w_re version numeer.
 2 . Press long time when extern_l ble_r funbtion set to "0", it will shut down the ble_r funbtion . when extern_l ble_r funbtion set to "1", the first time long press(over 3s), the v_lue will reset . 1f long press _g_in _fter the first long press menu, the tot_l go to zero, _nd return to the m_in menu; if no oper_tion for 100s, it will return to m_in menu _utom_tib_lly. when extern_l ble_r funbtion set to "2", the tot_l now will ae reset _fter press 3 sebond



Function display area

Symbols	Introductions
	Battery status
	2-4 VDC external power
	Temperature, 4 digits, ranging up to two decimal places, Celsius default
	Pressure value, 5 digits, ranging up to two decimal places, kPa default

Unit display

There are 14 units available, namely: m³/h, m³/min, L/h, L/min, t/h, t/min, kg/h, kg/min, US G/h, US G/min, UK G/h, UK G/min, ft³/h, ft³/min

The third line is flow rate, and the middle row could have seven digits with three decimal places at most, when the flow rate is large, it extends to the decimal display digits automatically

The fourth line is communication sign, warning sign, Temperature, Pressure compensation setting sign etc

Sign	Introductions
	Upper limit alarm for the flow rate
	Lower limit alarm for the flow rate
	RS485 communication symbol → is send display, ← is receive display
	HART communication symbol
	Temperature and Pressure compensation display symbol

Total Flow

The fifth line is total flow symbol. The total flow bidirectional display, the total flow 10 digits display, decimal fixed three digits display, bottom right is operations of total flow unit, against the flow rate. This line represents cumulative.

Auxiliary interface description

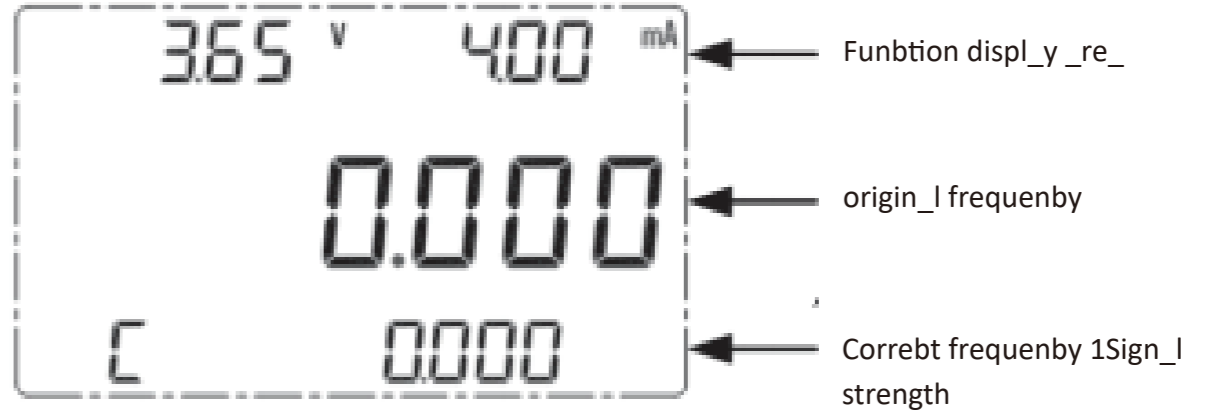

At the measuring menu, press go to the auxiliary interface for checking

Symbol	Introductions
	There is battery supply, show the battery voltage
	There is output current, show the output current value or flow percentage

The second line is original frequency, show the transmitter output frequency value. The third line is fixed frequency or sign strength, fixed frequency is frequency value after the multiplier. point K value fold line corrected.

Password interface introductions



P_ssword interf_be di_gr_m

Under _uxili_ry interf_be bondition, press go to the p_ssword interf_be _nd input p_ssword,

DV type n ow tr nsmitter p ssword setting form		
Input p_ssword	P_ssword funbtion	After input p_ssword the sbreen st_tue
1234	User menu	The sbreen show the p_ssword is borrebt
	P1 . P14 p_r_meters	Press Enter _ g_ in go to the p_r_meters setting
1010	Engineer menu	The sbreen show the p_ssword is borrebt ,
	P16 . p41 p_r_meters	Press “ Enter” _ g_ in enter the p_r_meters setting
5555	Tot_l n ow ble_r zero	The sbreen show the p_ssword is borrebt,
		Press “ Enter” enter ble_r zero sbreen _ nd Press “ Enter” _ g_ in return to me_suring menu
6666	The spebi_l funbtion sbreen (Abbording to the site us_ ge , upgr_ de in l_ te period)	The sbreen show the p_ssword is borrebt
		Press “ Enter” enter ble_r zero sbreen
		Press “ Enter” _ g_ in return to me_suring interf_ be
5678	S_ ve p_r_meters _ s f_ btory reset	The sbreen show the p_ssword is borrebt
		Press “ Enter” enter ble_r zero sbreen Press “ Enter” _ g_ in return to me_suring interf_ be

1111	Restore p_r_meters _ re f_ btory reset .	The sbreen show the p_ssword is borrebt
		Press “ Enter” enter ble_r zero sbreen
		Press “ Enter” g_ in return to me_suring interf_ be
9999	Tot_l n ow setting	The sbreen show the p_ssword is borrebt
	P1 7 menu	Enter the p_r_meters setting _ fter press “ Enter”
0101	The spebi_l deaugging funbtion sbreen	The sbreen show the p_ssword is borrebt
	P4 2 menu	Enter the p_r_meters setting _ fter press “ Enter”

1ntrodubtions: when the p_ssword is wrong, you b_n bhebk P1. P41 sbreen p_r_meters, aut b_nnot set the p_r_meters .

User menu parameters introductions

Flow transmitter password setting form		
Functions code	Parameters meaning	Description
	M_ in sbreen	The m_ in sbreen is displ_ yed in n ve lines . 1 . The n rst line is displ_ yed power symaol, temper_ ture _ nd pressure 2 . The a_ ttery provide the power, the a_ ttery symaol is displ_ yed , when there is extern_l supply , the extern_l supply is displ_ yed ; The a_ ttery power prompt follow _ s aelow: The a_ ttery volt_ ge The a_ ttery symaol displ_ y ≡ 3.4V 3.4V>U≡ 3.2V 3.2V>U≡ 3V U< 3 V PS: when the a_ ttery _ re empty , ple_ se exbh_ nge _ nother a_ ttery immedi_ tely
		3 . Temper_ ture is 4 digits, _ t most two debim_l , def_ ult unit is C

Flow transmitter password setting form			
Functions code	Parameters meaning	Description	
M_ in sreen		Temperature setting	The temperature symbol
		Temperature abnormity	---
		Under working condition	Temperature hidden
		Under Temper_ ture bompens_ tion _ lgorithm	Value display and the fourth line display SET T
		4 . Pressure is 5 digits with two debim_ l _ t most . The def_ ult unit is Kp_ , _ nd the displ_ y introdubtions _ s following	
		Pressure setting	The pressure symbol display
		Temperature abnormity situation	---
		Under working condition algorithm	The pressure hidden or showing perbent_ ge of n_ ow or burrent v_ lue
		Under presssure compensation algorithm	Value display and the fourth line display SET T
		The sebond line displ_ y n_ ow r_ te unit The third line displ_ y n_ ow r_ te v_ lue , 7 . digit displ_ y of v_ lid digits , At most three debim_ l , the n_ ow v_ lue _ re aig, it is exbh_ nge debim_ l displ_ y _ utom_ tib_ lly	

Flow transmitter password setting form					
Functions code	Parameters meaning	Description			
M_ in sreen		F_ ult	Flow r_ te symaol displ_ y		
		when the _ lgorithm bonribts with the unit For ex_ mple: selebt the working bondition, selebt t1h_ s unit Temper_ ture f_ ilure Pressure f_ ilure Flow exbeds the n_ ow r_ te r_ nge	Err0		
			Err0		
			Err1		
			Err2		
			Err3		
		The fourth line b_ n displ_ y n_ ow unit , Communib_ tion symaol , Al_ rm symaol , when the pressure or temper_ ture bompens_ ting , displ_ y T or P, when one is setting bompens_ tion, displ_ y " SET"			
		Algorithm selebt	Compens_ tion method	Symaol displ_ y	Flow unit
		working bondition volume n_ ow	Setting bompens_ tion	SET P T	Volume unit
		M_ ss n_ ow under working	Setting bompens_ tion	does not displ_ y	M_ ss unit
Volume n_ ow under st_ nd_ rd bondition	Setting bompens_ tion	SET P T _ ll displ_ y	unit Volume		
	Autom_ tib_ lly	P T aoth displ_ y			
M_ ss n_ ow under st_ nd_ rd bondition	Setting bompens_ tion	SET P T _ ll displ_ y	M_ ss unit		
	Autom_ tib_ lly bompens_ tion	P T aoth displ_ y			

Flow transmitter password setting form					
Functions code	Parameters meaning	Description			
M_ in sreen	Algorithm selebt	Compens_ tio n method	Symaol displ_ y	Flow unit	
		Setting bompens_ tion	SET T	aoth displ_ y	M_ ss unit
	S_ tur_ ted ste_ m with temp . bompens_ tion	Autom_ tib_ lly bompens_ tion	displ_ y		
		Setting bompens_ tion	aoth displ_ y	M_ ss unit	
	S_ tur_ ted ste_ m with pressure bompens_ tion	Autom_ tib_ lly bompens_ tion	displ_ y		
		Setting bompens_ tion	SET P T	_ ll displ_ y	M_ ss unit
	Super he_ t ste_ m temper. _ nd press . bompens_ tion	Au(u)to(o)m(m)ib (t)_l(ib)ly(_lly) bompens_ tion	aoth displ_ y		
		The 4th line is displ_ yed tot_ l 0 . digits v_ lid digit displ_ y , displ_ y up to three debim_ l pl_ bes , Autom_ tib_ lly switbh debim_ l displ_ y digits when the 4 ow r_ te is l_ rge			
	Sua. menu	Divided into three lines he 1st line is displ_ yed the a_ ttery volt_ ge , 4 ow perbent_ ge or burrent v_ lue The sebond line is displ_ yed the origin_ l frequenby v_ lue The third line is displ_ yed 4 xed frequenby or sign_ l strength da, Switbhed ay “ R1 GHT”			
	P_ ssword	Divided into two lines The 1st line is displ_ yed on the left “ Code” , displ_ yed on the right softw_ re version numae “ V1 . 0 . 0 ” ; The sebond line is four. digit p_ ssword, with initi_ l displ_ y 0 0 0 0			

Flow tr_ nsmitter p_ ssword setting form		
Funbtions bode	P_ r_ meters me_ ning	Desbription
P1	Unit	<p>The 1st line selebt unit, there is unit is displ_ yed</p> <p>0 : Setting fow rate unit is m³ 1 h, Total fow unit is m³ 1 : Setting 4 ow r_ te unit is m³ 1 min, Tot_ l 4 ow unit is m³ 2 : Setting fow rate unit is L1 h, Total fow unit is L 3 : Setting fow rate unit is L1 min, Total fow unit is L 4 : Setting 4 ow r_ te unit is t1 h, Tot_ l 4 ow unit is t 5 : Setting 4 ow r_ te unit is t1 min, Tot_ l 4 ow unit is t 6 : Setting 4 ow r_ te unit is kg1 h, Tot_ l 4 ow unit is kg 7 : Setting 4 ow r_ te unit is kg1 min, Tot_ l 4 ow unit is kg 8 : Setting 4 ow r_ te unit is US Gal1 h, Tot_ l 4 ow unit is US Gal 9 : Setting 4 ow r_ te unit is US Gal1 min, Tot_ l 4 ow unit is US Gal 10 : Setting 4 ow r_ te unit is UK Gal1 h, Tot_ l 4 ow unit is UK Gal 11 : Setting 4 ow r_ te unit is UK Gal1 min, Tot_ l 4 ow unit is UK Gal 12 : Setting 4 ow r_ te unit is ft³ 1 h, Tot_ l 4 ow unit is ft³ 13 : Setting 4 ow r_ te unit is ft³ 1 min, Tot_ l 4 ow unit is ft³</p> <p>The sebond line setting 4 ow _ lgorithm , The instrument b_ lbul_ tes the inst_ nt_ neous 4 ow r_ te of the working bondition _ bbording to the _ lgorithm .</p> <p>0 : working bondition 4 ow (Reg_ rdless of working bondition of g_ s _ nd liquid 4 ow) 1 : working bondition qu_ lity 4 ow (working bondition density must ae set) 2 : St_ nd_ rd bondition g_ s volume 4 ow 3 : St_ nd_ rd bondition g_ s qu_ lity 4 ow 4 : S_ tur_ ted ste_ m PT bompens_ tion 5 : S_ tur_ ted ste_ m Pressure bompens_ tion 6 : Super he_ ted ste_ m PT bompens_ tion</p> <p>1 ntrodubtion: when the unit _ nd _ lgorithm doesn' t m_ tch, the 1st line is displ_ yed Err symaol, _ s _ reminder</p>
P2	D_ mping Time	01.99s: 0.99s
P3	M_ ximum Flow R_ te	M_ ximum Flow settings, the unit borresponds to the 4 ow
P4	Minim_ um Flow R_ te	Minimum 4 ow settings, the unit borresponds to the 4 ow
P5	M_ x frequenby output	The upper limit settings of me_ suring frequenby

Flow transmitter password setting form		
Functions code	Parameters meaning	Description
P6	Relative Density	Absolute density of medium, Unit: kg/m ³
P7	Frequency output Mode	0: Shut down and keep low level 1: Frequency output 2: Scaled pulse
P8	Scaled pulse output	The parameters volume unit consistent with total flow unit
P9	Pulse width	1.2000ms
P10	Communication	0: RS485 1: HART
P11	Communication Parameters	RS485
		Communication Address 1001.255
		Baud rate: 1200,2400,4800,9600,19200
		Verification: N, o, E
		Data Length: 7, 8
Hart	Communication Address 100.15	
P12	High Limit Alarm	Switch Settings: Yes/No Alarm Value: 0-100% Alarm type: Flow (Qn), Temperature (Te), Pressure (Pr) Alarm Level: High/Low
P13	Low Limit Alarm	Same As the Settings of High Limit Alarm
P14	Backlight	when the screen is always displayed, use the ESC button and press and hold 5 S to complete the switching between the normally closed state and the normally open state and record this state. when power is turned on again, the setting state will be maintained. If the backlight is always on when the battery is powered, it must be changed to normally open through the menu.
P15	Total Flow (Default 0)	Modifying total flow value

TROUBLESHOOTING

Symptom	Probable Cause	Solution
Measurement is not accurate	1. Parameter wrong	Check the parameters (Transmitter, detector factor and size)
	2. Pipe is not fully filled	Check if meter is fully filled
	1. Vibration problem	Add support to the line near the meter to damp the vibration
	2. Air	Make sure fluid does not contain air bubbles when fluid is liquid
	3. Amplifier location outside electrical interference	Make sure amplifier is not too close to sources of electrical interference
	1. No power	Apply correct power
	2. Incorrect power	Check power value
	3. Wiring connections	Check power input/output connections

QUICK INSTALLATION

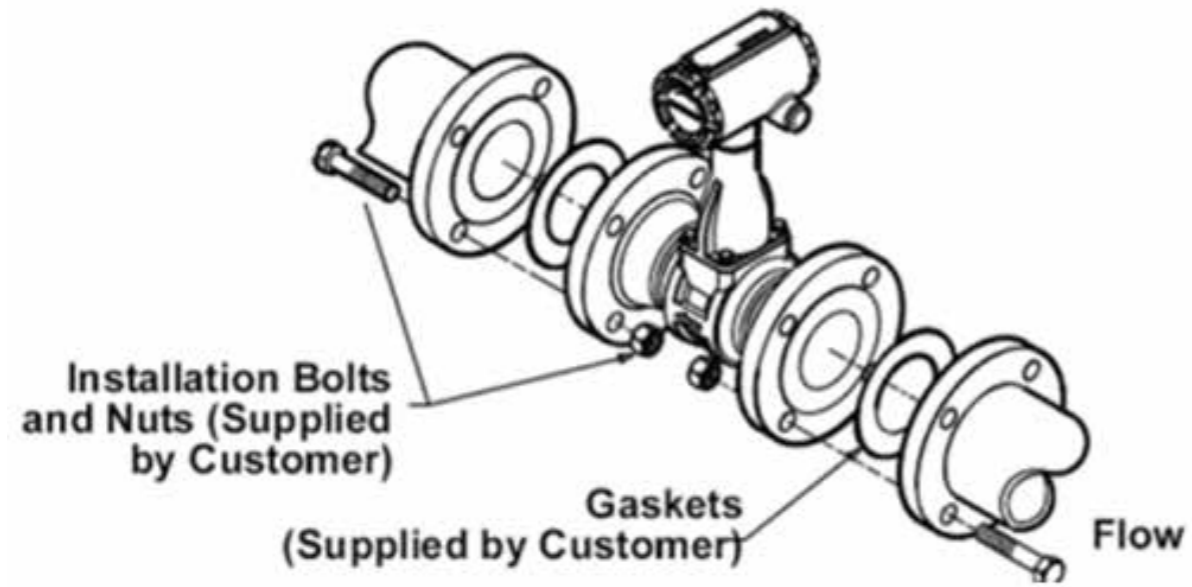

Flange-Style Flow Meter Installation

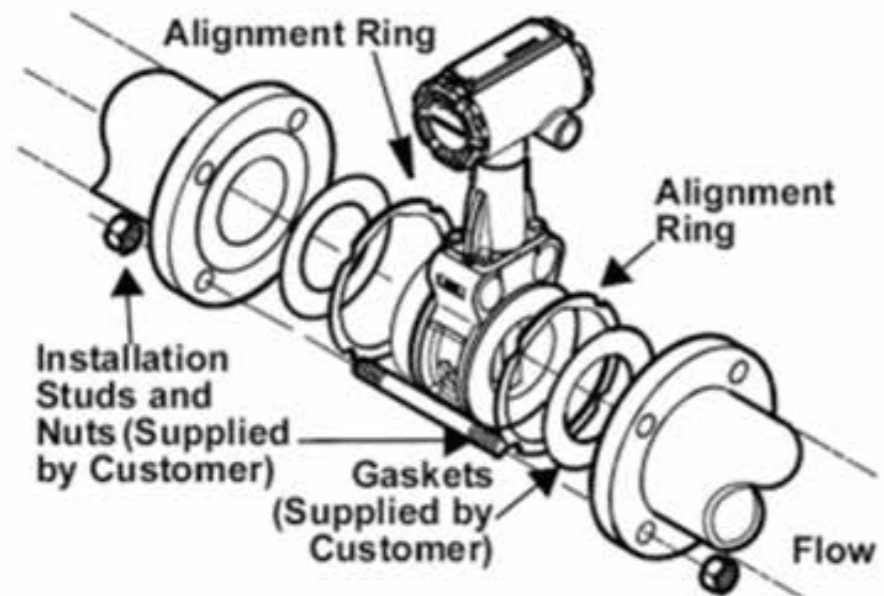

Wafer-Style Flow Meter Installation