

Certificates



XI'AN YUNYI INSTRUMENT COMPANY LIMITED



- 1. Pressure Transmitter
- 2. Pressure Gauge
- 3. Pressure Calibrator
- 4. Dead Weight Tester
- 5. Level Transmitter
- 6. Flow Transmitter
- 7. Temperature Transmitter
- 8. Density Meter

Liquid Turbine Flow Meter

User Manual



Warning

When the flow meter is installed at explosion hazard field, DON'T remove the COVERPLATE when the meter is powered. Please make parameter setting at safe filed prior to installation.



Special Notices

Pictures & Descriptions are for your information only, please refer to the actual product. Parameters are subjected to changes without notice.

GENERAL INFORMATION

This manual will assist you in installing, using and maintaining your turbine flow meter. It is your responsibility to make that all operators have access to adequate instructions about safe operating and maintenance procedure.



Warning

For your safety, review the major warnings and cautions below before operating your equipment

Use only fluids that are compatible with the housing material and wetted components of your turbine.

When measuring flammable liquids, observe precautions against fire or explosion.

When handling hazardous liquids, always follow the liquid manufacturer's safety precautions.

When working in hazardous environments, always exercise appropriate safety precautions.

During turbine removal, liquid may spill. Follow the liquid manufacturer's safety precautions for clean up of minor spills.

Do not blow compressed air through the turbine.

Handle the rotor carefully. Even small scratches or nicks can affect accuracy.

When tightening the turbine, use a wrench only on the wrench flats.

For best results, calibrate the meter at least 1 time per year.

Product Description

YUN YI series turbine flow meters have the features: high accuracy, good repeatability, convenient installation/maintenance, simple structure etc.

Liquid flows through the turbine housing causing an internal rotor to spin. As the rotor spins, an electrical signal is generated in the pickup coil. This signal is converted into engineering units (liters, cubic meters, gallons etc.) on the local display where is applicable. Optional accessory modules can be used to export the signal to other equipment. Upon receipt, examine your meter for visible damage. The turbine is a precision measuring instrument and should be handled carefully. Remove the protective plugs and caps for a thorough inspection. If any items are damaged or missing, contact

Make the turbine flow model meets your specific needs. For your future reference, it might be useful to record this information on nameplate in the manual in case it becomes unreadable on the turbine. Refer to the nameplate for your customized product's specification.

SPECIFICATIONS

Performance

Repeatability: $\pm 0.2\%$
 Accuracy: Standard: $\pm 1\%$ of reading;
 Optional: $\pm 0.5\%$ of reading

Wetted Components

Housing: Standard - 304 Stainless Steel
 Optional - 316 Stainless Steel
 Bearings and Shaft: Tungsten Carbide
 Rotor: Standard - 2Cr13 Stainless Steel (Optional Alloy CD4Mcu)
 Retaining Rings: 316 Stainless Steel

Output Signal: (Where applicable)

Sensor: Pulse signal (Low Level: $\leq 0.8V$; High Level: $\geq 8V$)
 Transmitter: 4 to 20 mA DC current signal

Signal Transmission Distance: $\leq 1,000$ m

Electrical Connections:

Basic Type: Hirschmann Connector or three-core cable
 Explosion Proof Type: ISO M20 \times 1.5 Female

Explosion Proof Level:

Standard: None
 Optional: ExdIIBT6

Protection Level: IP65

OPERATION CONDITIONS

Ambient:

Temperature:
 Pressure: 86 to 106 KPa
 Relative Humidity: 5% to 90%

Power Supply:

Sensor: +12V DC (Optional: +24V DC)
 Transmitter: +24V DC
 Field Display Type B: Integral 3.2V Lithium Battery (Others available on request)
 Field Display Type C: +24V DC

Fluid Temperature and Pres:

Temperature: $-20^{\circ}C$ to $+110^{\circ}C$
 Pres: Fluid pres should be limited according to rating.

Measurable Flow Rate Range and Pres Level: (See table 1)

Table 1. Measurable Flow Range and Pressure Rating

Nominal Diameter		Standard Flow Range (SFR)	Extended Flow Range (EFR)	Standard Pres Rating	Customized Pres Rating
(mm)	(in.)	(m ³ /h)	(m ³ /h)	(MPa)	(MPa) - Flange Fitting
4	0.15	0.04 to 0.25	0.04 to 0.4	Thread: 6.3	12, 16, 25
6	0.25	0.1 to 0.6	0.06 to 0.6	Thread: 6.3	12, 16, 25
10	0.4	0.2 to 1.2	0.15 to 1.5	Thread: 6.3	12, 16, 25
15	0.5	0.6 to 6	0.4 to 8	Thread: 6.3; Flange: 2.5	4.0, 6.3, 12, 16, 25
20	0.75	0.8 to 8	0.45 to 9	Thread: 6.3; Flange: 2.5	4.0, 6.3, 12, 16, 25
25	1	1 to 10	0.5 to 10	Thread: 6.3; Flange: 2.5	4.0, 6.3, 12, 16, 25
32	1.25	1.5 to 15	0.8 to 15	Thread: 6.3; Flange: 2.5	4.0, 6.3, 12, 16, 25
40	1.5	2 to 20	1 to 30	Thread: 6.3; Flange: 2.5	4.0, 6.3, 12, 16, 25
50	2	4 to 40	2 to 40	Flange: 2.5	4.0, 6.3, 12, 16, 25
65	2.5	7 to 70	4 to 70	Flange: 2.5	4.0, 6.3, 12, 16, 25
80	3	10 to 100	5 to 100	Flange: 2.5	4.0, 6.3, 12, 16, 25
100	4	20 to 200	10 to 200	Flange: 1.6	4.0, 6.3, 12, 16, 25
125	5	25 to 250	13 to 250	Flange: 1.6	2.5, 4.0, 6.3, 12, 16
150	6	30 to 300	15 to 300	Flange: 1.6	2.5, 4.0, 6.3, 12, 16
200	8	80 to 800	40 to 800	Flange: 1.6	2.5, 4.0, 6.3, 12, 16

Model Selection

Model No.										Definition
YUNYI-	□	/□	/□	/□	/□	/□	/□	/□	/□	
Type	4									DN4
	6									DN6
	10									DN10
	15									DN15
	20									DN20
	25									DN25
	32									DN32
	40									DN40
	50									DN50
	65									DN65
	80									DN80
	100									DN100
	125									DN125
	150									DN150
200									DN200	
Connection	FL									Flanged
	LW									Threaded
	JZ									Clamp-on by flange
Nominal diameter(mm)			N							24V power supply, no field display, pulse output
			A							24V power supply, field display, 4-20mA output
			G1							Battery powered, field display, no output
			GX							External power supply, field display, RS485/current/pulse output
			E1							Battery powered, field display, no output
			EX							External power supply, field display, RS485/current/pulse output
Accuracy				05						Standard range
				10						Extended range
				02						Special range
Range					S					0.5
					W					1.0
					Z					0.2(by customized, long production period)
Meter material					S					304 SS
					L					316(L) SS
Impeller material						S				2Cr13 impeller
						L				Duplex steel impeller
Explosion-proof grade							N			Non-explosion proof
							E			Exd II BT6 Gb
Temperature and pressure resistant							N			Standard
							H(x)			High pressure

Notes: DN20, DN32, DN65, DN125 are custom. X refers to number(s), standing for different functions. Contact us for details.

CAUTIONS FOR INSTALLATION

Mounting Positions

Turbine flow meters should be installed at the place in compliance with the requirements below:

- Easy maintenance
- No vibration
- No electromagnetic interface
- Away from heat source

Mounting Orientation

All turbine flow meters are designed to measure flow in only one direction. The direction is indicated by the arrow on the body.

Required Lengths of Straight Runs

Flow altering device such as elbows, valves and reducers can affect accuracy. See diagram 1 for typical flow meter system installation.

Diagram 1. Typical Flow Meter System Installation

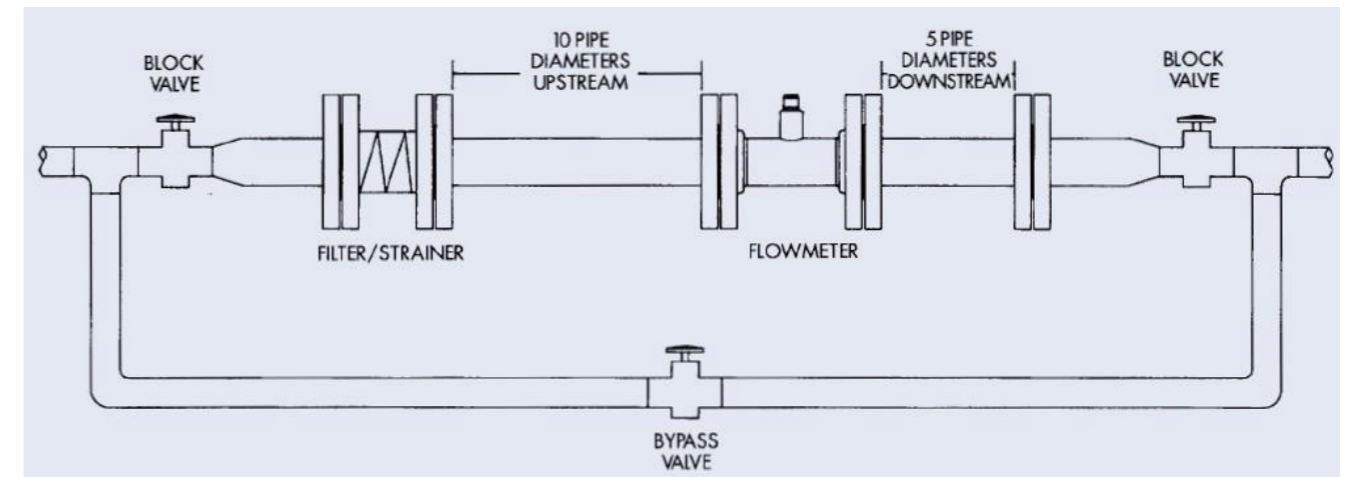

The recommended guidelines are given to enhance accuracy and maximize performance. Distance given here are minimum requirements; double them for desired straight pipe lengths.

- Upstream: allow a minimum straight pipe length at least 10 times the internal diameter of the pipe. For example, with the 50mm pipe, there should be 500mm of straight pipe immediately upstream. Desired upstream straight pipe length is 1000mm.
- Downstream: allow a minimum straight pipe length at least 5 times the internal diameter of the pipe. For example, with the 50mm pipe, there should be 250mm of straight pipe immediately upstream. Desired upstream straight pipe length is 500mm

See diagram 2 for straight pipe length requirement when there is altering device.

Diagram 2. Number of Pipe Diameter (D=Diameter)

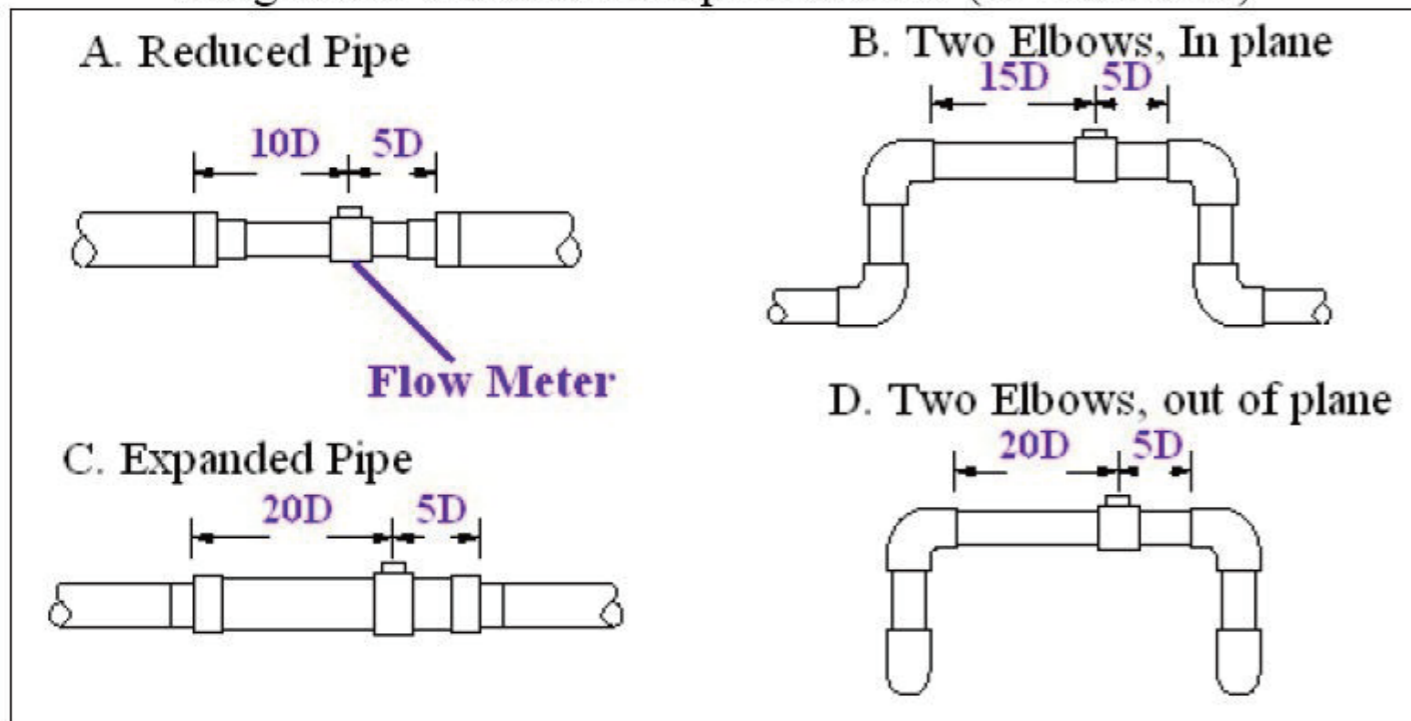

Thread Connections

- To protect against leakage, seal all threads with an appropriate sealing compound. Make the sealing compound does not intrude into the flow path.
- Make the arrow on the outlet is pointed in the direction of the flow.
- Tighten the turbine onto the fittings. Use a wrench only on wrench flats.

Flange Connections

For standard product, the flange follows GB/T 9119-2000 (ISO 7005-1) RF (Raised Face).

Note: flange can be customized following other criteria.

Use a gasket between the meter flange and mating flange. Determine the material of the gasket based on the operating conditions and type of fluid.

Note: Do not over tighten the flange bolts. This may cause the gasket to be compressed into the flow stream and may decrease the accuracy of the meter.

INSTALLATION DIMENSIONS

Thread or flange connection is used according to different flow models.

Thread connection dimensions

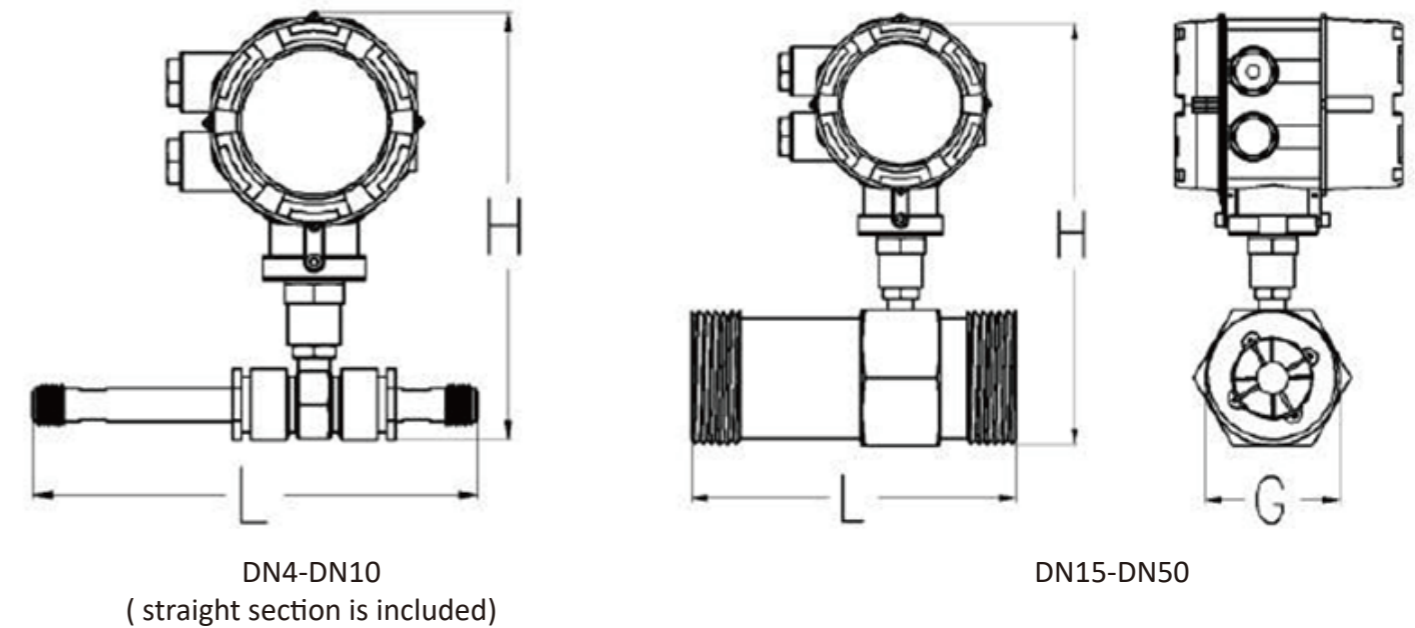

Warning: Precaution for direct sunshine and rain when the meter is installed outside.

Anti-Cavitation

Cavitation can be caused by entrained air, and it can seriously damage the rotor on a turbine flow meter. An amount higher than about 100 mg/l of entrained air or gas can produce error. In addition, cavitations can be caused by too little back pres on the flow meter. For turbine flow meters, you should provide a back pres (downstream pres) of at least 1.25 times the vapor pres, plus 2 times the pressure drop through the flow meter. See formula 1.

$$\text{Formula 1: } P_b \geq 1.25 \times P_v + 2 \times (P_{in} - P_{out})$$

In formula 1: (P_b: Back pres; P_v: Vapor Pres; P_{in}: Inlet Pres; P_{out}: Outlet Pres)

Create back pres by installing a control valve on the downstream side of the meter at the proper distance detailed above.

Special Notice

- Foreign material in the liquid being measured can clog the meter's rotor and adversely affect accuracy. If this problem is anticipated or experienced, install screens to filter impurities from incoming liquids.
- To ensure accurate measurement, drain all air from the system before use.
- When the meter contains removable cover plates. Leave the cover plate installed unless accessory modules specify removal. Don't remove the cover plates when the meter is powered, or electrical shock and explosion hazard can be caused.

Diameter (mm)	L (mm)	H(mm)				G male Thread
		Pulse Type	Pulse Type with Ex.	4-20mA Type with Ex	Intelligent Display Type	
4	225	140	145	145	210	G1/2
6	225	140	145	145	210	G1/2
10	345	145	150	145	210	G1/2
15	75	145	150	150	215	G1
20	80	150	155	155	220	G1
25	100	155	160	160	225	G1-1/4
32	140	175	180	180	245	G2
40	140	180	185	180	250	G2
50	150	185	190	190	255	G2-1/2

Notice: The straight section is included for DN4-DN10, but not DN15-DN

Flange connection

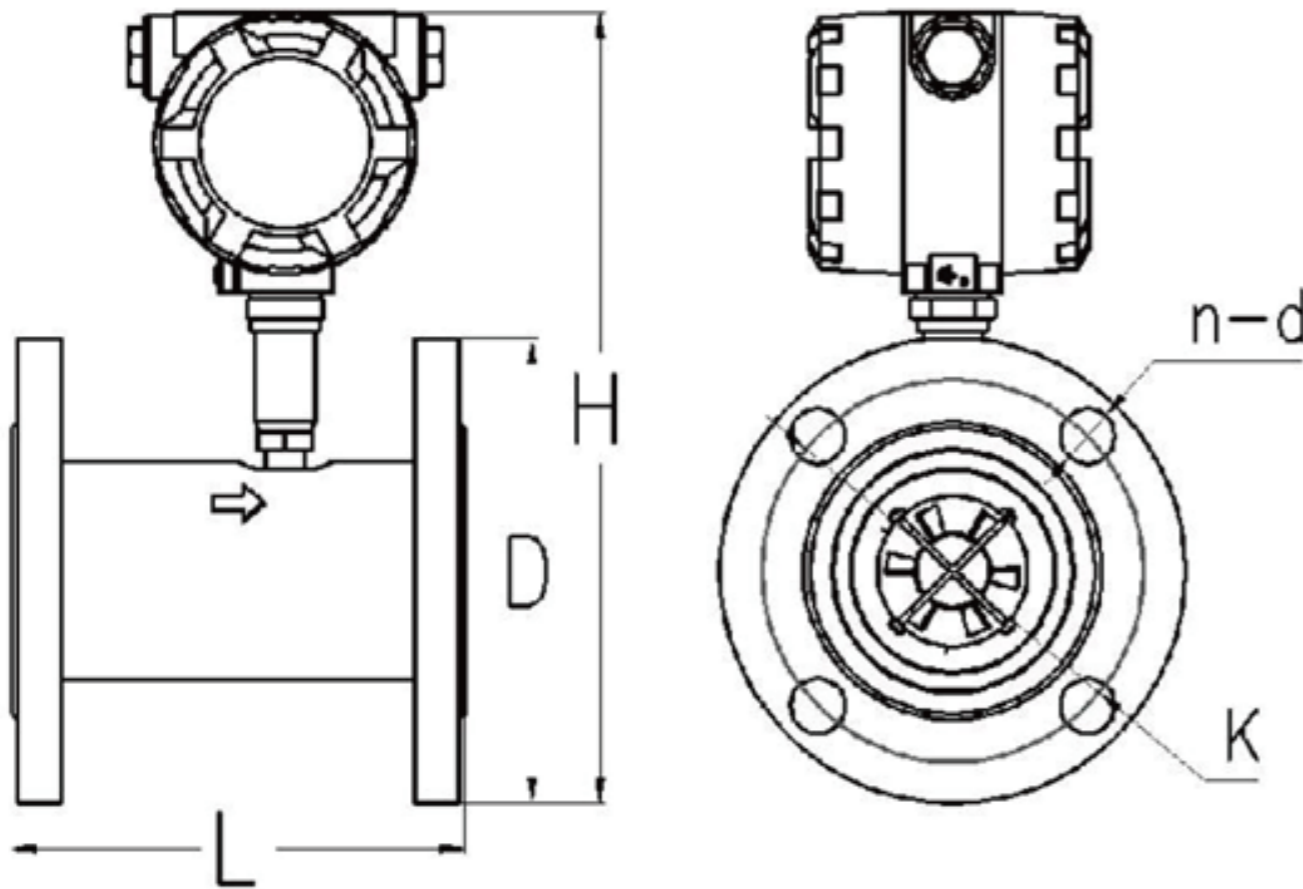

Diameter (mm)	L (mm)	D (mm)	K (mm)	H(mm)				d (mm)	n	Press. Rate
				Pulse Type	Pulse Type with Ex.	4-20mA Type with Ex	Intelligent Display Type			
15	75	95	65	175	180	180	245	14	4	2.5Mpa
20	80	105	75	185	190	190	255	14	4	
25	100	115	85	200	195	195	260	14	4	
32	140	140	100	210	215	215	275	18	4	
40	140	150	110	195	220	220	285	18	4	
50	150	165	125	230	235	235	295	18	4	
65	170	185	145	255	260	260	325	18	4	1.6Mpa
80	200	200	160	260	265	265	330	18	8	
100	220	220	180	285	285	285	350	18	8	
125	250	250	210	310	315	315	380	18	8	
150	300	285	240	345	345	345	410	22	8	
200	360	340	295	395	400	400	465	22	12	

Wafer Connection

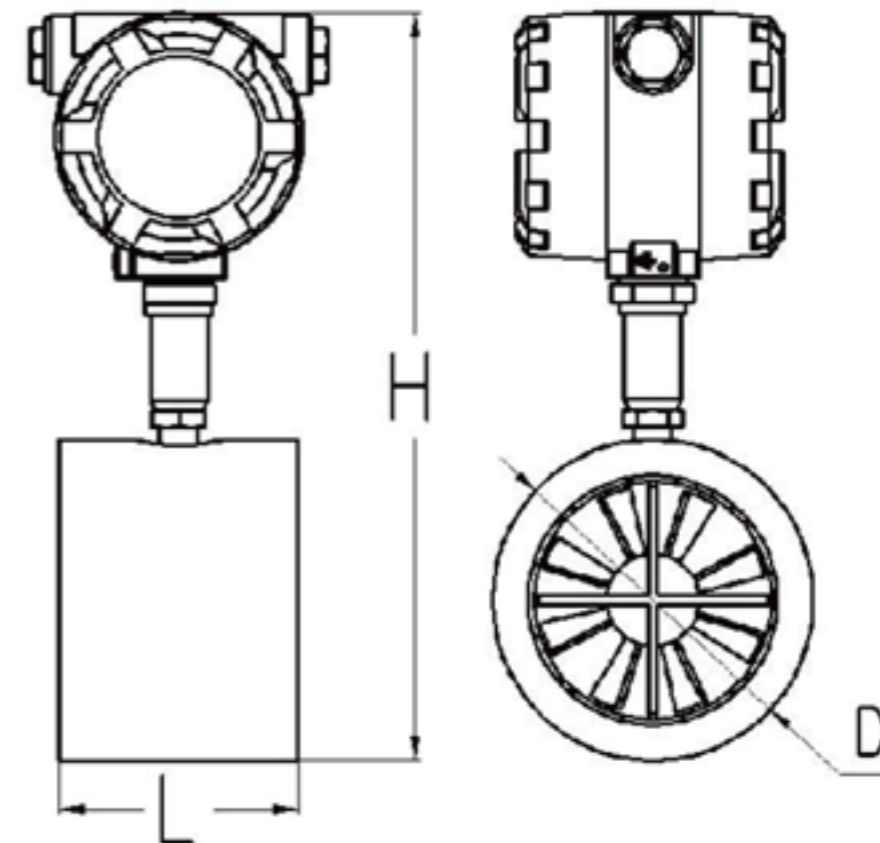

Diameter (mm)	L (mm)	D (mm)	H(mm)			
			Pulse Type	Pulse Type with Ex.	4-20mA Type with Ex	Intelligent Display Type
4	50	38	145	X		215
6	50	38	145			215
10	50	38	145			215
15	55	47	155			220
20	60	53	160			225
25	60	58	165			230
32	70	66	170			240
40	70	72	180			245
50	70	92	195			260
65	80	100	205			210
80	90	112	220	225	225	290
100	100	137	245	250	250	310
125	120	165	270	275	275	340
150	150	190	295	300	300	365
200	150	243	350	350	350	415

Diameter (mm)	L (mm)	D (mm)	A (mm)	B (mm)	b (mm)	H(mm)						
						Pulse Type	Pulse Type with Ex.	4-20mA Type with Ex	Intelligent Display Type			
4	50	50.5	46	40.5	4	145	150	150	210			
6					6	145	150	150	210			
10					10	145	150	150	210			
15	100				15	155	160	160	225			
20					20	160	160	160	225			
25					25	160	165	165	230			
32					32	165	165	165	230			
40	140				64	59	110	40	175	180	180	245
50	150				78	73.5	125	50	185	190	190	255
65	170				91	86	145	65	205	205	205	270
80	200	106	100.5	160	80	215	220	220	285			
100	220	119	113	180	100	235	240	240	305			

Sanitary Connection

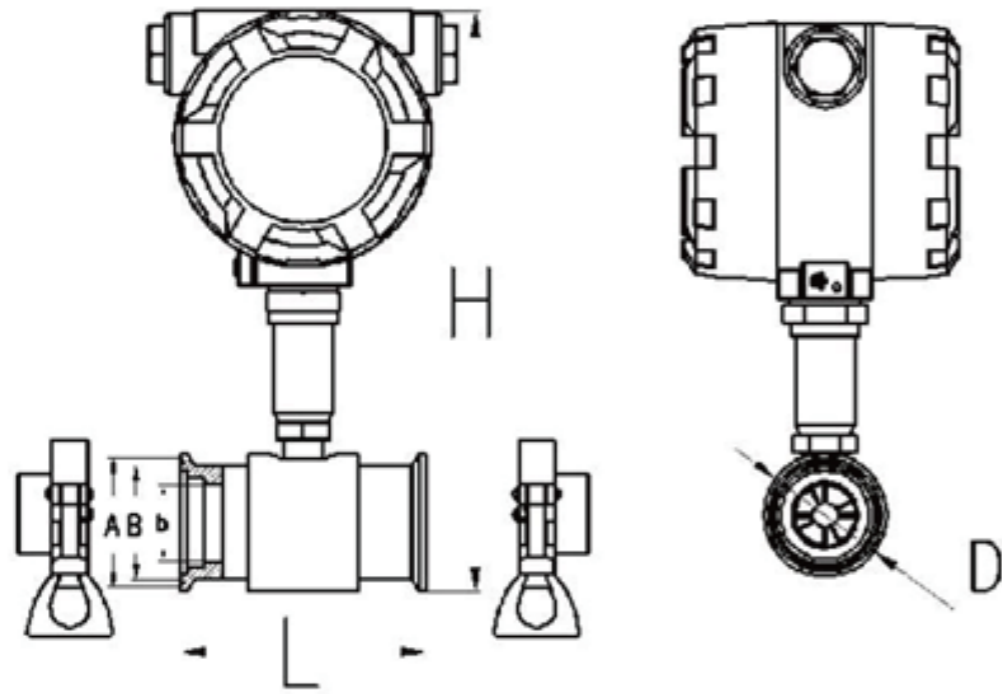



Warning: Electrical Hazard
Disconnect power before beginning installation.

Turbine Flow Sensor/Transmitter

- 1. Pulse Type without Explosion Proof

Terminal wiring

Terminal Symbols	Description
Red Wire	Power Supply: "24V+"
White Wire	Power Supply: "24V-"
Yellow Wire	Pulse Output

- 2. Pulse with Explosion Proof:

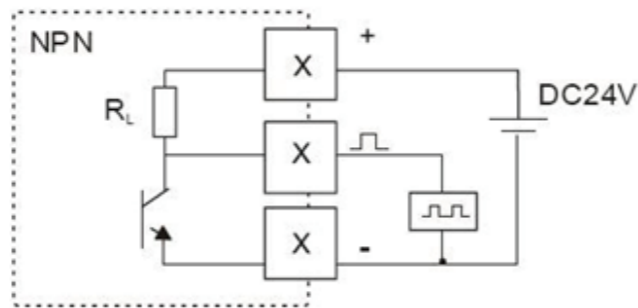
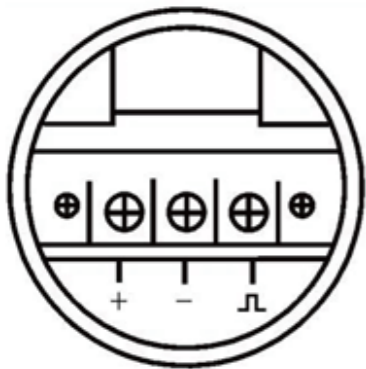

- Notice: (1) High level amplitude >22V
(2) Low level amplitude <0.8V
(3) Load capacity >1100Ω
(4) Pulse frequency ≤3000Hz

- 3. 4-20mA Output with Explosion Proof Type

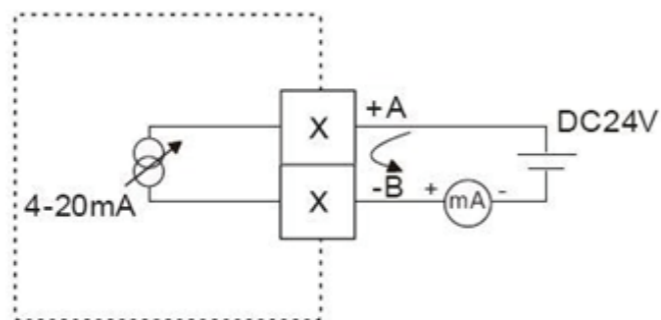
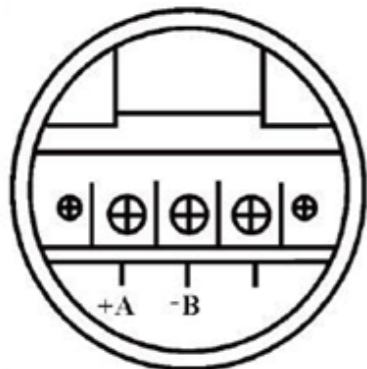

Notice: Load resistor is <

- 4. Function table for the Intelligent display type

Main Power	Display	Output						
		Pulse * 1	Scale d Pulse * 2	Current				Modbus RS485
				2-wire 4~20 mA	3-wire 4-20 mA	4-wire 0-20m	4-wire 4~20m A	
Battery*3								
24V DC								
24V C+Battery*4								
220Vac								
Description of the symbols:			Default Function				Optional	

Notice:

- The pulse means the signal which is in direct proportion to the impeller speed.
- The scaled Pulse means the signal when the flow rate reach ONE unit volume (m³, L, 0.01L...)
- The batter model is ER34615
- The battery model is ER26500

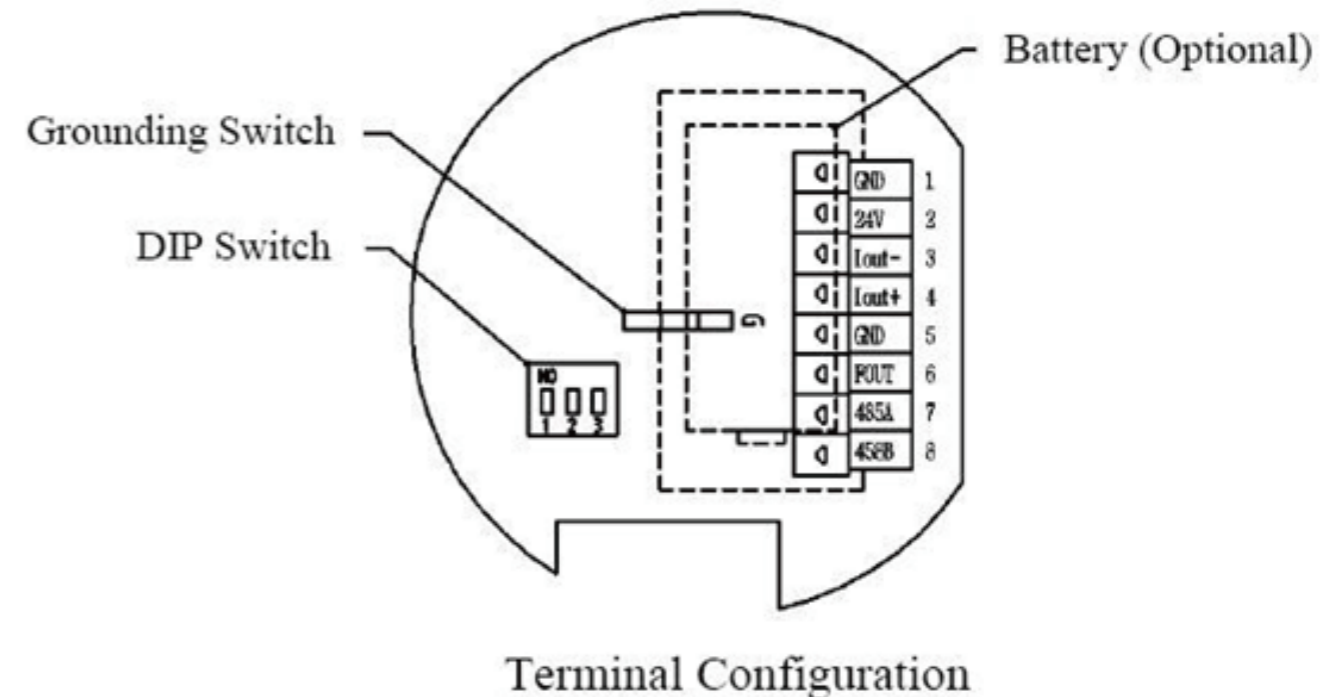

Terminal Configuration

Terminal No.	Terminal Symbols	Description
1	GND	24V- DC Power Supply
2	24V	24V+ DC Power Supply
3	lout-	Current Output 4 to 20 mA DC (-)
4	lout+	Current Output 4 to 20 mA DC (+)
5	GND	24V- DC Power Supply
6	-FOUT	F-OUT: Pulse output
7	485A	RS485-
8	485B	RS485+

(3 Wire) 4-20mA Output

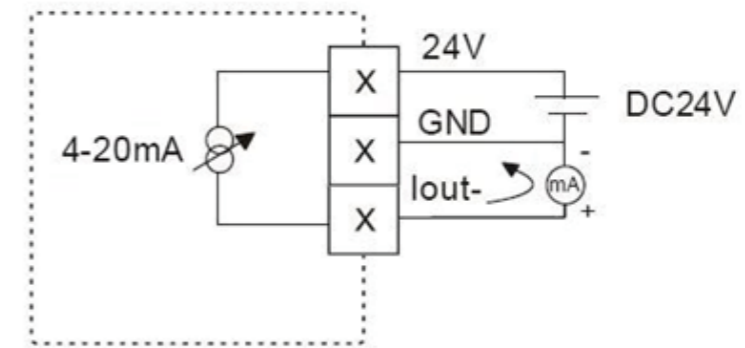

(3 Wire) 0-20mA Output

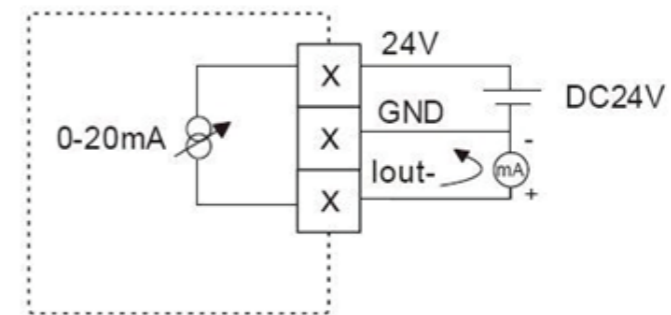

Notice: Load resistor is <math>< 500\Omega</math>

RS485 communication

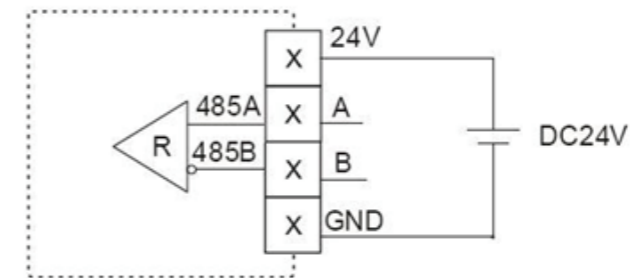

Notice: The communication format is Modbus-RTU protocol

220Vac powered type

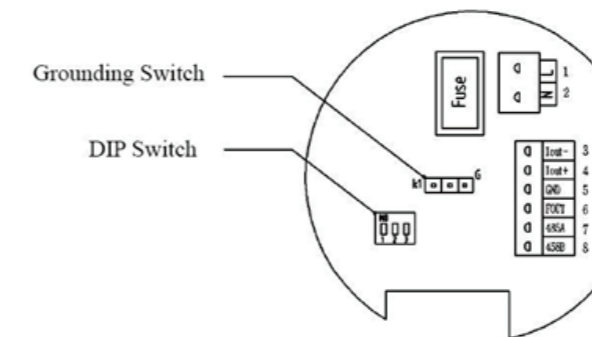

Terminal Configuration

Pulse / Scaled Pulse output

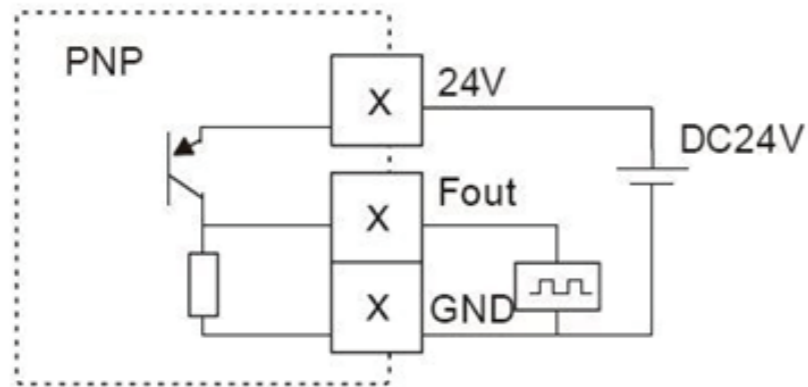

- Notice: (1) High level amplitude >22V
- (2) Low level amplitude <0.8V
- (3) Load capacity >1100Ω
- (4) Pulse frequency ≤3000Hz

(2 Wire) 4-20mA Output

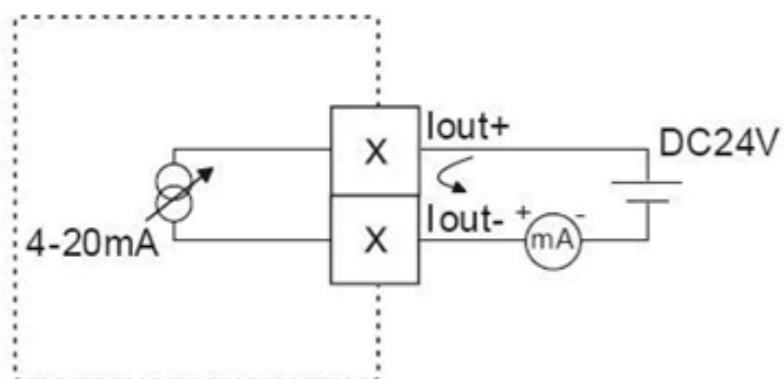

Terminal Configuration

Terminal No.	Terminal Symbols	Description
1	L	AC 220V Power Supply
2	N	AC 220V Power Supply
3	Lout-	Current Output
4	Lout+	Current Output
5	GND	Current / Pulse output -
6	FOUT	FOUT: Pulse output
7	485A	RS485-
8	485B	RS485+

Pulse / Scaled Pulse output

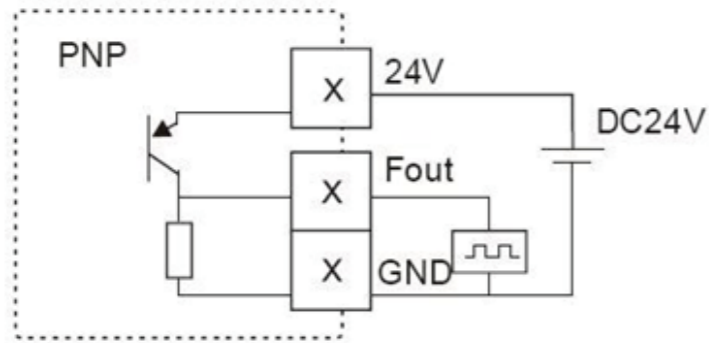

Notice: Three conditions are necessary for pulse output High level amplitude >22V Low level amplitude <0.8V Load capacity >1100Ω Pulse frequency ≤ 3000H

(4 Wire) 4-20mA Output

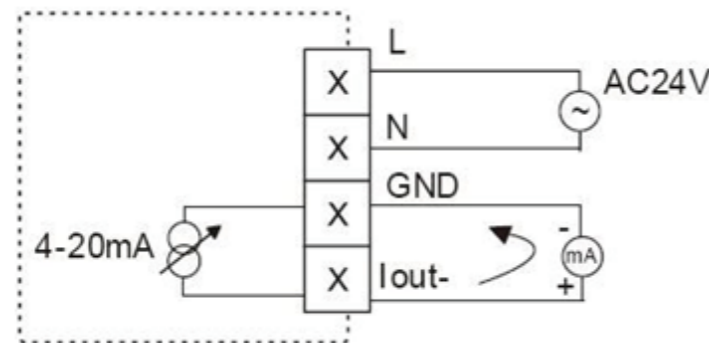

(4 Wire) 0-20mA Output

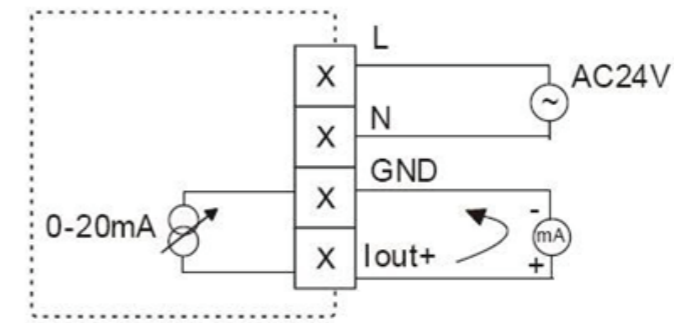

RS485 communication

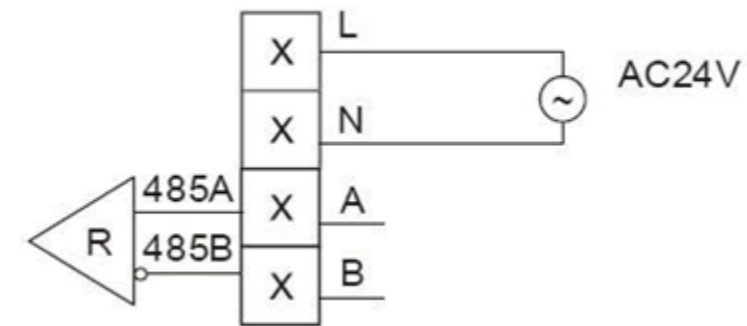

Function table for

DIP Switch: K1			
Function	1	2	3
Original Pulse Output	ON	OFF	OFF
Scaled Pulse Output: 1 m ³ / Pulse	OFF	ON	OFF
Function Reserved	OFF	OFF	ON

Parameter set

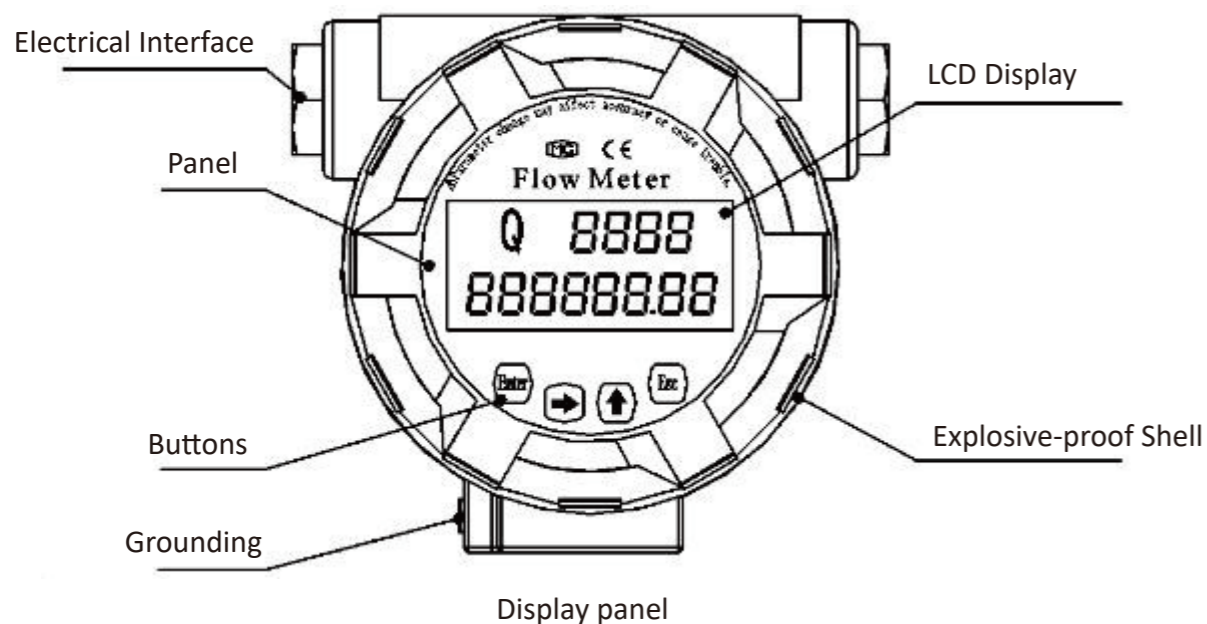

There are four keys: "Enter", "→", "↑", "Esc".

KEYS	Description
Enter	Save the value and advance to next menu
→	For numerical values, move cursor position
↑	To change number unit, setting
Esc	Return to measuring model

Description of Password Grade

Password	Description
1234	Modify parameters
5555	Total rate reset

Description of menu

Menu	Parameter	Setting Method	Grade	Description		
				Value	Flow Unit	Total Flow Unit
F-1	Unit	Select parameter	User	0	M3/h	M3
				1	L/h	L
				2	L/min	L
				3	US Gal/min	US Gal
				4	UK Gal/min	UK Gal
				5	US Gal/h	US Gal
				6	UK Gal/min	UK Gal

				7	KG/h	Kg
				8	t/h	T
				9	Ft3/h	Ft3
F-2	Damp time	Input value	User	Unit: Second Value: 0~99s		
F-3	Max flow rate	Input value	User	Unit: The same to the F-1		
F-4	Min flow rate	Input value	User	When the flow rate lower than min flow rate, the flow rate will display 0; The unit is the same to the F-1		
F-5	Max frequency output	Input value	User	Accuracy: 0.1Hz		
F-6	Density	Input value	User	When need to display mass unit, it needs to input the density of liquid. The unit of density is g/cm3		
F-7	Pulse output	Select parameter	User	1: Original pulse output 2: Corrected pulse		
F-8	Scaled pulse	Select parameter	User	0.001: 0.01 unit volume / pulse 0.01: 0.01 unit volume / pulse 0.1: 0.1 unit volume / pulse 1: 1 unit volume / pulse		
F-9	Pulse width	Input value	User	The value is between 0005-2000 range, and it's multiple of 5 with ms unit;		
F-10	Communication	Select parameter	User	Address: 1-247 Baud rate: 1200, 2400, 4800, 9600, 19200		
F-11	Baud	Select parameter	User	N(No verify) O(Odd verify) E(Even verify) Data length: 7,8 Stop bits length: 1,2		
F-12	Total flow	Input value	User	It could be modified with right code		
P1	Linearization of the Flowcurve: point 1	Input value	Factory only	First Row: Corrected Frequency (F1) without decimal, F1 Second Row: Coefficient error with (K1) six decimals		
P2	Linearization of the Flowcurve: point 2	Input value	Factory only	First Row: Corrected Frequency (F2) without decimal, F1 Second Row: Coefficient error with (K2) six decimals		
P3	Linearization of the Flowcurve: point 3	Input value	Factory only	First Row: Corrected Frequency (F3) without decimal, F1 Second Row: Coefficient error with (K3) six decimals		
P4	Linearization of the Flowcurve: point 4	Input value	Factory only	First Row: Corrected Frequency (F4) without decimal, F1 Second Row: Coefficient error with (K4) six decimals		
P5	Linearization of the Flowcurve: point 5	Input value	Factory only	First Row: Corrected Frequency (F5) without decimal, F1 Second Row: Coefficient error with (K5) six decimals		
P6	Linearization of the Flowcurve: point 6	Input value	Factory only	First Row: Corrected Frequency (F6) without decimal, F1 Second Row: Coefficient error with (K6) six decimals		
P7	Linearization of the Flowcurve: point 7	Input value	Factory only	First Row: Corrected Frequency (F7) without decimal, F1 Second Row: Coefficient error with (K7) six decimals		
P8	Linearization of the Flowcurve: point 8	Input value	Factory only	First Row: Corrected Frequency (F8) without decimal, F1 Second Row: Coefficient error with (K8) six decimals		
P9	Coefficient	Input value	Factory only	First Row: Corrected Frequency with one decimal, F1 Second Row: Coefficient error with two decimals, unit : /L, K		

Parameter set

Symptom	Probable Cause	Solution
Measurement is not accurate	1. Turbine operated below minimum rate. 2. Turbine partially clogged with dried liquid 3. Installed too close to fittings.	Increase flow rate. Refer to Section 3.0 Operation Conditions Remove turbine. Clean carefully. Make rotor spins freely. Install correctly. Refer to Section 5.0 Cautions for Installation
LCD Display Abnormality	1. Battery Power Type: Bad contact on the connector between battery and PCB 2. DC Power Type: supply voltage is abnormal	Open back cover and repower the flow meter Check and en power supply is 24V DC

METER CONSTRUCTION

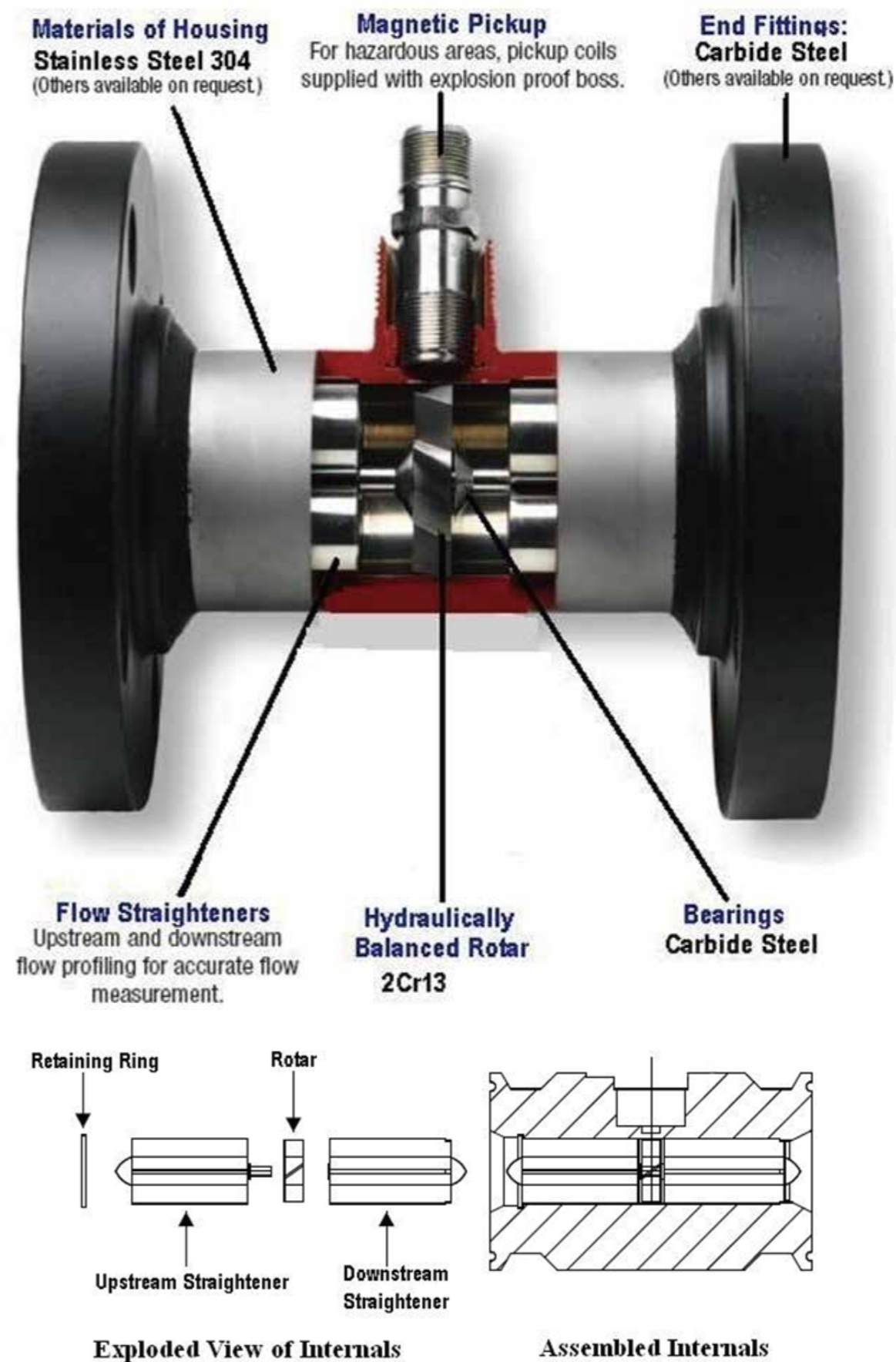

METER CONSTRUCTION

Hereby provides a limited warranty against defects in materials and workmanship. This product includes a one-year warranty. The warranty period shall begin on the date of the original new equipment purchase. Warrantor's obligation hereunder shall be limited to repairing defective workmanship or replacing or repairing any defective parts.

In the event Purchaser believes the product is defective, the product must be returned to, transportation prepaid by Purchaser, within the appropriate warranty period relative to the product. If 's inspection determines the workmanship or materials are defective and the required maintenance has been performed and,has been properly installed and operated,the product will be either repaired or replaced, at 's sole determination,free of additional charge, and the goods will be returned,transportation paid by , using a transportation method selected by .

Prior to returning the product to , Purchaser must obtain a Returned Material Authorization(RMA) Number from 's Customer Service Department within 30 days after discovery of a purported breach of warranty, but not later than the warranty period;otherwise,such claims shall be deemed waived.

If 's inspection reveals the product to be free of defects in material and workmanship or such inspection reveals the goods were improperly used, improperly installed,and/or improperly selected for service intended,will notify the purchaser in writing and will deliver the goods back to Purchaser upon receipt of Purchaser's written instructions and agreement to pay the cost of transportation. If Purchaser does not respond within thirty (30) days after notice from , the goods will be disposed of in 's discretion.

does not warrant the product to meet the requirements of any safety code or other jurisdiction,and Purchaser assumes all risk and liability whatsoever resulting from the use thereof, whether used singly or in combination with other machines or apparatus.

This warranty shall not apply to any product or parts thereof,which have been repaired outside 's factory or altered in any way,or have been subject to misuse,negligence, or accident,or have not been operated in accordance with 's printed instructions or have been operated under conditions more severe than,or otherwise exceeding,those set in the specifications.

FOR NON- WARRANTY REPAIRS OR CALIBRATIONS,consult for current repair/calibration charges. Have the following information available BEFORE contacting :

- 1.P.O. number to cover the COST of the repair/calibration, 2.Model and serial number of the product, and
- 3.Repair instructions and/or specific problems relative to the product.