



certificates



XI'AN YUNYI INSTRUMENT COMPANY LIMITED



- 1. Pressure Transmitter
- 2. Pressure Gauge
- 3. Pressure Calibrator
- 4. Dead Weight Tester
- 5. Level Transmitter
- 6. Flow Transmitter
- 7. Temperature Transmitter
- 8. Density Meter

ELECTROMAGNETIC FLOW METER USER MANUAL



YFM4800E



YFM-4800



YFM-4880E



YFM-4880

Product description

YFM Smart electromagnetic flow meter is a high-performance, high-reliability flow meter. It used to measure the volume flow of conductive liquid and slurry in closed pipelines. Widely used in steel, electricity, petroleum, chemical industry, coal, metallurgy, papermaking, water supply and drainage, food, pharmaceutical industry, etc.

Working principle

The measuring principle of electromagnetic flow meter is based on Faraday's law of electromagnetic induction. The sensor is mainly composed of a measuring tube with an insulating lining, a pair of electrodes installed by inserting the measuring tube wall, a pair of coils and an iron core to generate a working magnetic field. When a conductive fluid flows through the measuring tube of the sensor, a voltage signal proportional to the average flow rate of the fluid will be induced on the electrode. The signal is operationally amplified and processed to achieve various display functions.

Features

- Measurements are not affected by fluid density, viscosity, temperature, pressure and conductivity.
- No obstacles in the measuring tube, no pressure loss, low requirements for straight pipe section.
- The LCD backlight type converter can be easily displayed and read in the sun or in a dark room.
- In harsh environments, parameters can be set via infrared touch buttons without opening the cover of the converter (need to be customized).
- Flow meter with bidirectional measurement system, built-in three totalizers: positive total, reverse total and total difference.
- It has various forms of output: current 4-20mA, pulse, frequency, rs-485, HART.
- The converter has self-diagnosis alarm output, no-load detection alarm output, flow upper and lower limit alarm, batch control (need to be customized) and other alarm output functions.
- Not only for general processes, but also for the measurement of ore pulp, mud, coal slurry, paper pulp and paste liquid.
- High-pressure electromagnetic flow sensor with PFA lining technology, resistant to high pressure and negative pressure, especially suitable for petroleum, chemical and other industries.
- Explosion-proof instruments can be used in corresponding explosion-proof places.

Technical parameter

Item	Technical parameter	
Main power	AC220V 50HZ/DC24V/DC12V/3.3V battery power supply	
Power consumption	<15W (Supporting power consumption with sensors)	
Display and buttons	Display in Chinese and English, can display instantaneous flow, accumulated flow and alarm display (excitation open circuit alarm, empty pipe alarm, flow over limit alarm). Four membrane touch switches for data setting	
Counter	Forward total, reverse total	
Output signal	Analog output	Two-way, fully isolated 0~10mA/4~20mA Load resistance: 0~1.5kΩ when 0~10mA; 0~750Ω when 4~20mA
	Frequency output	Forward and reverse flow output, the upper limit of output frequency can be set within 1~5000Hz. Open collector bidirectional output of transistor with photoelectric isolation. The external power supply is not greater than 35V, and the maximum current of the collector when it is turned on is 50mA
	Alarm Output	Two-way open collector alarm output with photoelectric isolation transistor. The external power supply is not greater than 35V, and the maximum current of the collector when it is turned on is 250mA. Alarm status: fluid empty pipe, excitation disconnection, flow overrun
	Pulse output	Forward and reverse flow output, the output pulse upper limit can reach 5000CP/S. Pulse equivalent is 0.0001~1.0m³/P. The pulse width is automatically set to 20ms or square wave. Open collector output of transistor with photoelectric isolation. The external power supply is not greater than 35V, and the maximum current of the collector when conducting is 50mA
Matching accuracy	0.5%	
Damping time constant	Continuous variable from 0~100s (90%) time grading optional	
Communication	Optional RS232C or RS485 serial communication interface, HART communication protocol	
Loss of power	The internal design of the instrument has a power-off clock, which can store 16 power-off records (10 years) (need to be customized)	
Protection class	IP65(standard);IP68 can be customized for the split type(only for transmitter).	
Explosion-proof mark	Ex d ia [ia Ga] q IIC T6 Gb	

Model Code Selection Table:

Code No.	Meter Type				
YFM-4800	Segregate Type Electromagnetic Flow Meter,				
YFM-4800E	Integrated Type Electromagnetic Flow Meter				
YFM-4880	Sanitary Segregate Type Electromagnetic Flow Sensor				
YFM-4880E	Sanitary Type Integrated Electromagnetic Flow Meter				
Code No.	Nominal Diameter	4800	4800E	4880	4880E
10	DN10mm	●	●	○	○
15	DN15mm	●	●	●	●
20	DN20mm	●	●	●	●
25	DN25mm	●	●	●	●
32	DN32mm	●	●	○	○
40	DN40mm	●	●	○	○
50	DN50mm	●	●	○	○
...	...	●	●	○	○
150	DN150mm	●	●	○	○
200	DN200mm	●	●	○	○
250	DN250mm	●	●	○	○
300	DN300mm	●	●	○	○
...	...	●	●	○	○
1200	DN1200mm	●	●	○	○
2000	DN2000mm	●	●	○	○
Code No.	Power Supply	4800	4800E	4880	4880E
A	85V~265V AC	●	●	●	●
D	DC 24V	●	●	●	●
Code No.	Nominal Pressure	4800	4800E	4880	4880E
Y1	0.6MPa	●	●	●	●
Y2	1.0MPa	●	●	●	●
Y3	1.6MPa	●	●	●	●
Y4	2.5MPa	●	●	●	●
Y5	4.0MPa	●	●	●	●
Y7	16MPa(limited DN10-150)	●	●	○	○
Y8	20MPa(limited DN10-50)	●	●	○	○
Y9	25MPa(limited DN10-50)	●	●	○	○
Code No.	Nominal Pressure	4800	4800E	4880	4880E
R	0~10mA.DC	●	●	●	●
M	4~20mA.DC	●	●	●	●
C	Pulse+4-20mA	●	●	●	●
T	RS485 MODBUS RTU	●	●	●	●
Q	RS-232C	●	●	●	●
A	4 ~ 20mA +RS485 MODBUS protocol	●	●	●	●

H	4 ~ 20mA.DC HART protocol	●	●	●	●
G	GPRS wireless communications	●	○	●	●
Code No.	Lining Materials				
X2	Soft rubber	●	●	○	○
X3	Polychloroprene rubber	●	●	○	○
X4	Polyurethane rubber	●	●	○	○
X5	Teflon	●	●	○	○
X6	F46 poly perfluoro ethylene ally	●	●	●	●
Code No.	Electrode Materials				
B1	Stainless steel containing molybdenum	●	●	●	●
B2	Hastelloy B alloy (HB)	●	●	●	●
B3	Hastelloy C alloy (HC)	●	●	●	●
B4	Titanium Ti	●	●	●	●
B5	Tantalum Ta	●	●	●	●
B6	Platinum Pt	●	●	●	●
Code No.	The Sensor Housing And Flange Materials				
F1	Carbon steel	●	●	○	○
F2	Stainless steel	●	●	●	●
F3	Other materials	●	●	○	○
Code No.	Electronic Shell Protection Grade (Optional)				
P1	IP65(standard)	●	●	●	●
P2	IP68(By customized)	●	○	●	○
Code No.	The Grounding Ring (Optional)				
R	Three-electrode Type (Equal to ground ring)	●	●	●	●
Code No.	Explosion Proof Type (Optional)				
E	Explosion proof type(24v.DC)	○	●	○	●

Selection codes explanation

Model Code: YFM-4800E50DY3MX5B1F1P1RE-L

4800E	50	D	Y3	M	X5	B1	F1	P1	R	E	L
↓	↓	↓	↓	↓	↓	↓	↓	↓	↓	↓	↓
Type	Diameter	Supply Pressure	Output	Lining	Electrode	Housing	Grade	Ground	Explosion	Max	
					Proof	Flow					

Note: "●" on behalf of optional, "○" is mean not optional.

Flange connection structure and installation dimensions

Unit: mm

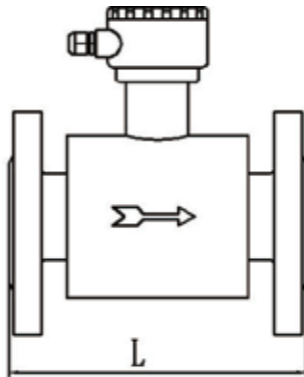
	DN	L(PTFE)	L(Rubber/PFA/F46)	D	d1	n*d0
	10	193	/	90	60	4*14
	15	193	/	95	65	4*14
	20	193	/	105	75	4*14
	25	193	/	115	85	4*14
	32	193	/	135	100	4*18
	40	193	200	145	110	4*18
	50	193	200	160	125	4*18
	65	243	250	180	145	4*18
	80	244	250	195	160	8*18
	100	244	250	215	180	8*18
	125	244	250	245	210	8*18
	150	290	300	280	240	8*23
	200	341	350	335	295	12*23
	250	441	450	405	355	12*26
	300	490	500	460	410	12*26
	350	490	500	505	460	16*23
	400	490	500	565	510	16*26
	450	540	550	615	560	20*26
	500	540	550	670	620	20*26
	600	590	600	755	705	20*25
	700	690	700	860	810	24*25
	800	790	800	975	920	24*30
	900	890	900	1075	1020	24*30
	1000	990	1000	1175	1120	28*30
	1200	1190	1200	1400	1340	32*34
	1400	1390	1400	1620	1560	36*34
	1600	1590	1600	1820	1760	40*34
	1800	1790	1800	2046	1970	44*41
	2000	1990	2000	2265	2180	48*48

(1) Instrument size error ± 2mm

(2) The rated flange pressure of this table DN10-DN300: 1.6MPa DN350-DN500: 1.0MPa ,DN600-DN2200: 0.6MPa.

(3) Other flange standards are customized.

Flange connection structure and installation dimensions

Flow range and Flow rate table								
m ³ /h mm	m/s	0.5	1	2	3	4	5	15(maximum)
10		0.14	0.28	0.27	0.85	1.13	1.41	4.24
10		0.14	0.28	0.27	0.85	1.13	1.41	4.24
15		0.32	0.64	1.27	1.91	2.54	3.18	9.54
20		0.57	1.13	2.26	3.39	4.52	5.65	16.96
25		0.88	1.77	3.53	5.30	7.07	8.84	26.51
32		1.45	2.90	5.79	8.69	11.58	14.48	43.43
40		2.26	4.52	9.05	13.57	18.10	22.62	67.86
50		3.53	7.07	14.14	21.21	28.27	35.34	106.03
65		5.97	11.95	23.89	35.84	47.78	59.73	179.19
80		9.05	18.10	36.19	54.29	72.38	90.48	271.43
100		14.14	28.27	56.55	84.82	113.10	141.37	424.12
125		22.09	44.18	88.36	132.54	176.71	220.89	662.68
150		31.09	63.62	127.23	190.85	254.47	318.09	954.26
200		56.55	113.10	226.19	339.29	452.39	565.49	1696.46
250		88.36	176.71	363.43	530.14	706.86	883.57	2650.72
300		127.23	254.47	508.94	763.41	1017.88	1272.35	3817.04
350		173.18	346.36	692.72	1039.08	1385.44	1731.80	5195.41
400		226.19	452.39	904.78	1357.17	1809.56	2261.96	6785.84
450		286.28	572.56	1145.11	1717.67	2290.22	2862.78	8588.33
500		353.43	706.86	1413.72	2120.58	2827.43	3534.29	10602.88
600		508.94	1017.88	2035.75	3053.63	4071.50	5089.38	15268.14
700		692.72	1385.44	2770.88	4156.33	5541.77	6927.21	20781.64
800		904.78	1809.56	3619.11	5428.67	7238.23	9047.79	27143.36
900		1145.11	2290.22	4580.44	6870.66	9160.88	11451.11	34353.32
1000		1413.72	2827.43	5654.87	8482.30	11309.73	14137.13	42411.50
1200		2035.75	4071.50	8143.01	12214.51	16286.02	20357.52	61072.56
1400		2770.88	5541.77	11083.54	16625.31	22167.08	27708.85	83126.54
1600		3617.11	7238.23	14476.46	21714.69	28952.92	36191.15	108573.44
1800		4580.44	9160.88	18321.77	27482.65	36643.54	45804.42	137413.26
2000		5654.87	11309.73	22619.47	33929.20	45238.93	56548.67	169646.00
2200		6842.39	13684.78	27369.56	41054.33	54739.11	68423.89	205217.66
2400		8143.01	16286.02	32572.03	48858.05	65144.07	81430.08	244290.24
2600		9556.72	19113.43	38226.85	57340.71	76453.71	95567.13	206701.40
2800		11083.54	22167.90	44334.15	66501.23	88668.31	110835.39	332506.16
3000		12723.45	25446.90	50893.80	76340.70	101787.60	127234.50	381703.50

Instrument installation

Choosing the correct installation location and adopting the correct installation method is the key to using the electromagnetic flow meter. If the installation is wrong, Not only will it affect the measurement effect, it will also affect the measurement accuracy, it will also affect the life of the flow meter, and even damage the flow meter.

Installation location selection

In order to make the sensor work reliable and stable, the following requirements should be paid attention to when choosing the installation location:

(1)Try to avoid ferromagnetic objects and equipment with strong electromagnetic fields (such as large motors, large transformers, etc.) to prevent magnetic fields from affecting transmission

The working magnetic field and flow signal of the sensor.

(2)It should be installed in a dry and ventilated place as much as possible , and not in a place with dampness and water.

(3)Avoid sun and rain as much as possible, and avoid ambient temperature higher than 60 °C and relative humidity higher than 95%.

(4)Choose a place that is convenient for maintenance and convenient for activities.

(5)The flow meter should be installed at the back of the pump, not on the suction side; the valve should be installed on the downstream side of the flow.

Installation requirements

For your correct measurement, you should pay attention to the following requirements when selecting the location on the pipeline:

(1)The sensor can be installed on a straight pipe, or on a horizontal or inclined pipe, but the center connection of the two electrodes is required in a horizontal state.

2) The medium should flow in the full pipe at the installation position to avoid dissatisfied pipe and gas adhering to the electrode.

(3)For liquid-solid two-phase fluids, it is best to install vertically to make the sensor lining wear evenly and prolong the service life.

(4)When the medium at the installation position of the flow meter is not full, the method of raising the back-end pipeline of the flow meter can be adopted to make it full.

Install flow meters at the high point and the water outlet.

(5)Modify the installation method of the pipeline: When the flow rate of the medium does not meet the requirements, a flow meter with a smaller diameter should be used.

Use reducer pipe or modify part of the pipe to make it the same diameter as the sensor, but the front and rear straight pipe sections must at least meet the front straight pipe section $\geq 10DN$, straight back pipe $\geq 5DN$ (DN is pipe diameter).

(6) The front and rear straight pipe sections are $\geq 10DN$ before the flow meter and $\geq 5DN$ at the back end.

Instrument wiring

- If the signal cable connected by split installation uses a customized dedicated cable, the shorter the cable, the better.
- The excitation cable can choose Yz medium-sized rubber sheathed cable, and its length is the same as the signal cable.
- Signal cables must be strictly separated from other power sources and cannot be laid in the same pipe.
- The signal cable and the excitation cable should be as short as possible, and the excess cables should not be rolled together. The excess cables should be cut off, and
- Re-solder the joints.
- When the cable mediates the sensor electrical interface, it is made into a U-shape at the port, which can prevent rainwater from penetrating into the sensor.



Install at the lowest point and vertical upward direction Don't install at the highest point and vertical downward direction

Install exhaust valve at the downstream of flow meter when drop is more than 5m

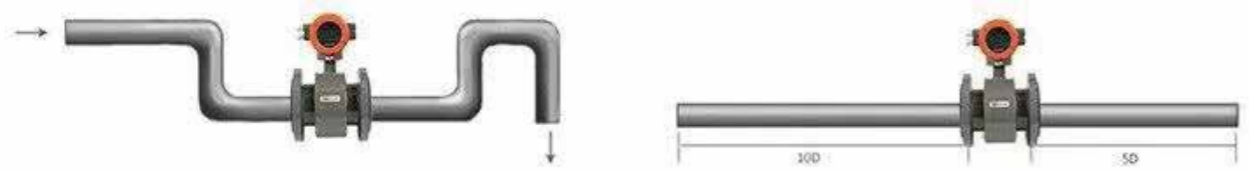

Installed at the lowest point when used in open drain pipe

Need 10D of upstream and 5D of downstream



The sensor cannot be installed at the inlet of the pump. It can be installed at the outlet

It should be installed on the rise of the pipeline

Electromagnetic Flow meter Converter Instruction Manual

The product function introduction

Basic function

- Low-frequency square-wave exciting, exciting frequency: 1/16 power frequency, 1/20 power frequency, 1/25 power frequency;
- High-frequency square-wave exciting, exciting frequency: 1/2 power frequency (for grouting liquid measure) ;
- Exciting current can be selected for 125mA, 187.5mA, 250mA, 500mA ;
- No need to add empty pipeline measurement, and can measure continuously, alarm by fixed value;
- Current speed range: 0.1 --- 15m/s, current speed resolution: 0.5mm/s;
- AC high-frequency switching power, range of voltage: 85VAC --- 250VAC;
- DC 24V switching power, range of voltage: 20VDC --- 36VDC;
- Network function: MODBUS, GPRS, PROFIBUS, Analog Loop Communication interface (choose) ;
- Chinese or English displaying mode, (other languages can be set);
- Three internal accumulators: positive total accumulation, reverse total accumulation, positive and negative accumulation difference.

Especial function

- Recording time when power turn-off, to record power broken time of instrument system automatically and recruit to count the missing flux ;
- Recording function of hourly gross, to record the flux gross by hour, fit for timed measure;
- Infrared handing remote control keyboard, all the functions of far-untouched controlling converter.

Normal operating conditions

- Ambient Temperature Ranges: fission $-10 \sim +60^{\circ}\text{C}$;
- Relative Humidity: 5% ~ 90%;
- Power Supply: 85 ~ 250V, 45 ~ 63Hz (single-phase AC).
- Dissipation Power: <20W (After connecting sensor) .

Type of connecting with sensors

- The integrated Circular shells: Circular shells, shells connect with the flange directly, explosion-proof;
- The integrated squared shells: squared shells, shells connect with the flange directly;
- The split squared shells: squared shells (hang on the wall), Signal converters connect with cable of sensor;

Plot of installing measure

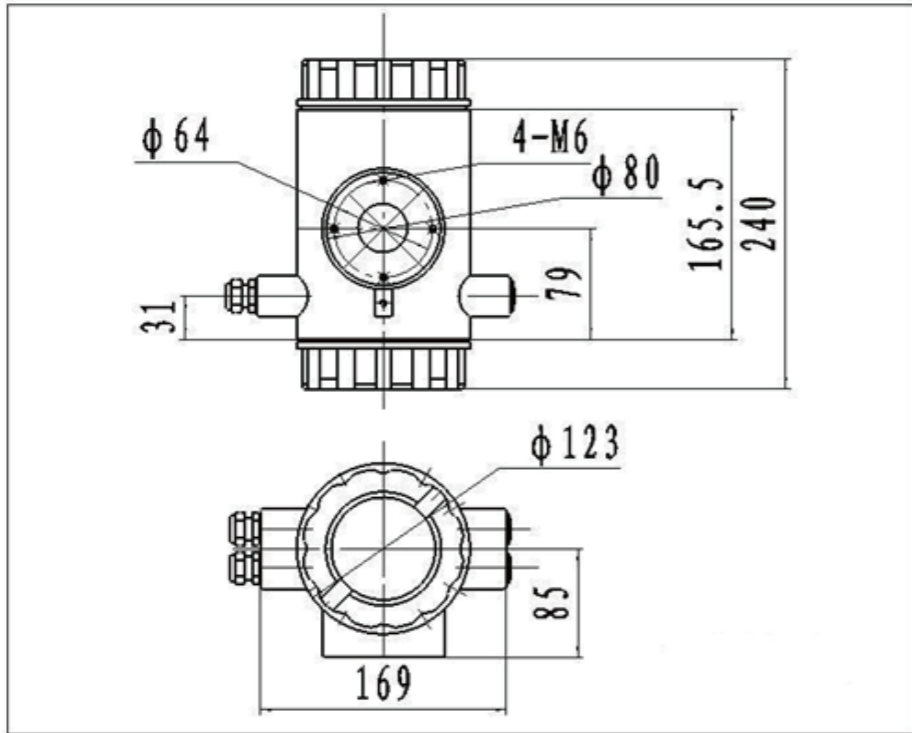

Fig.1 Exterior size of the integrated Circular shells

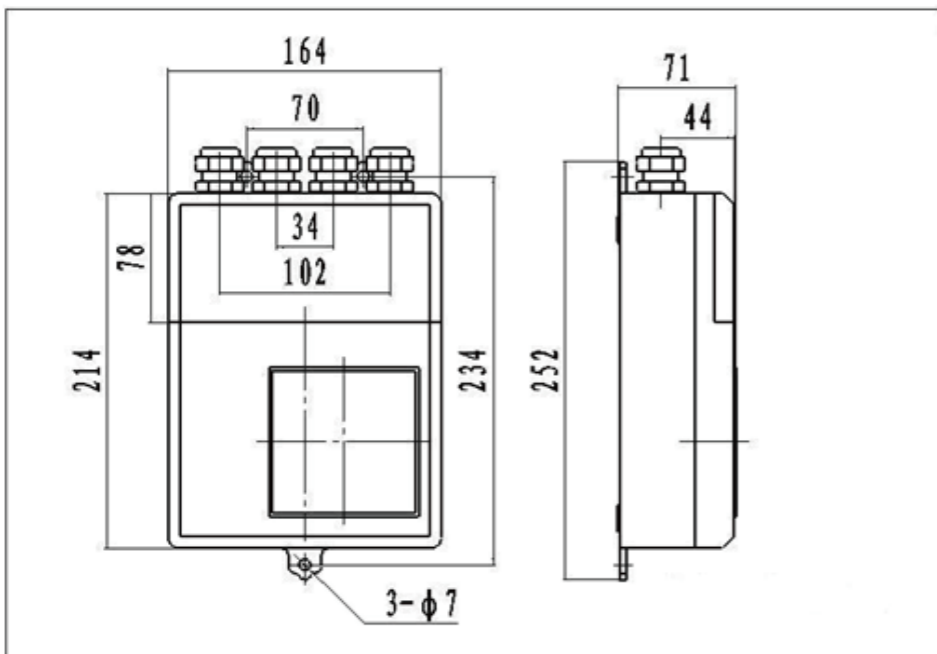

Fig.2 Exterior size of the split squared shells

Basic circuit of converter

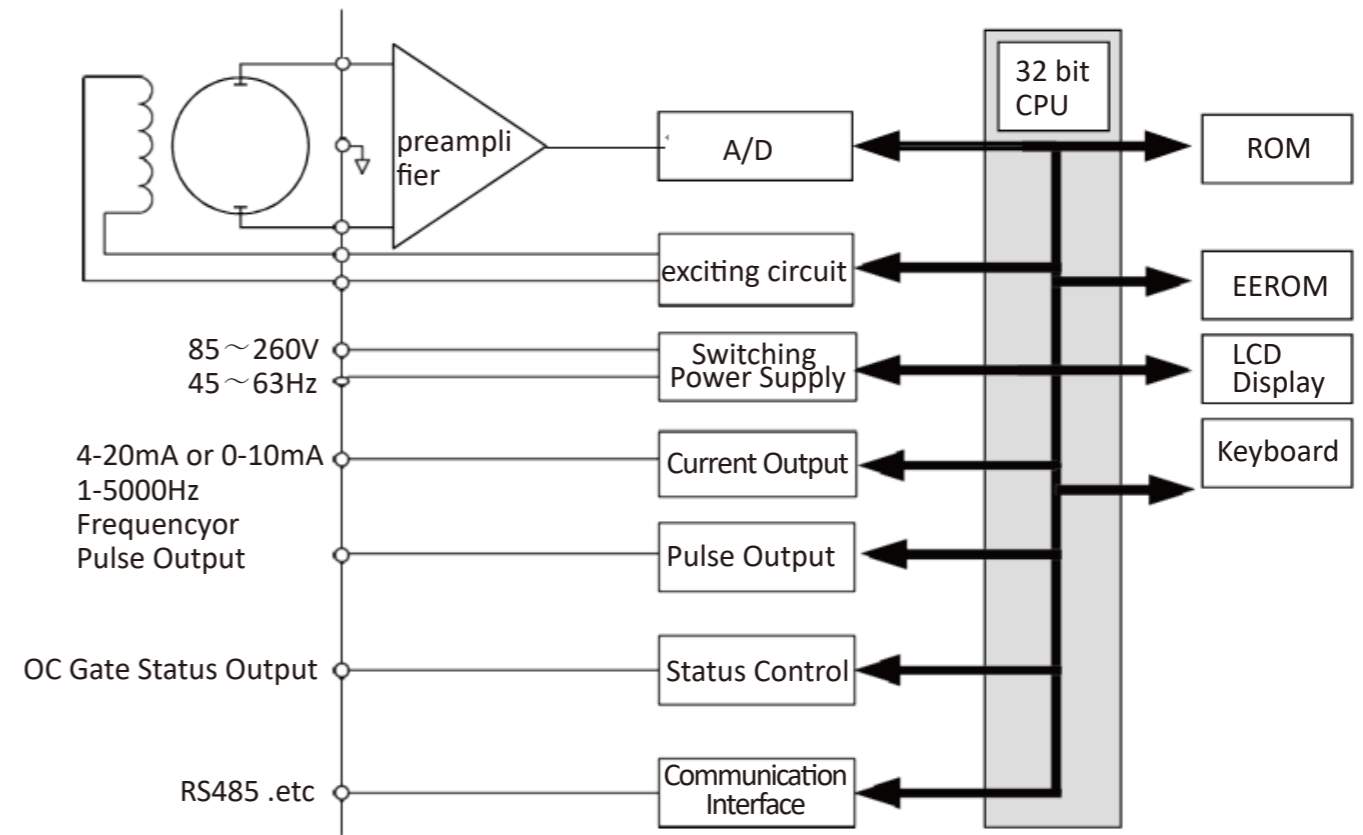

Fig.2. 1 Structure Of Converter's Circuit

The converter can supply exciting current to the coil in the sensor of electromagnetic Flow meter, the head amplifier amplifies the electromotive force from the sensor and converts it into standard signals of current or frequency so that the signals can be used for displaying, controlling and processing. See structure of converter circuit shown in Fig.2.1.

Index of technical performance

Standard of implement

The design, production and instrument of Electromagnetic Flow meter Converter implement «ISO 9104:1991» and «ISO 6817:1992» .

Basic parameters and performance index

Pipe's inside diameter of relative sensor (mm):

- 3,6,10,15,20,25,32,40,50,65,80,100,125,150,200,250,300,350,400,450,500,600,700,800,900,1000,1200,1400,1600,1800,2000,2200,2400,2500,2600,2800,3000;

Request of relative sensor

Sensitivity of sensor signal: under 1m/s, output 150 μ V ~200 μ V;

For electromagnetic flow meter signal converters, there are four currents of 62.5mA in exciting loop, which make up of 250mA, and every 62.5mA is controlled by one 20 Ω exact resistance. So user can choose different exciting current by changing the number of exact resistance.

The current will be 250mA when the signal converters leave factory, as such, if there are three exact resistance, the current will be 187.5 mA; if two, 125mA;

Resistance of sensor exciting coil:

500mA exciting current: 20 ~ 30 Ω ;

250mA exciting current: 50 ~ 60 Ω ;

187mA exciting current: 60 ~ 80 Ω ;

125mA exciting current: 100~20 Ω ;

Measure precision for assembly

Table 3.1 VS: Setting measurement range (m/s)

Diameter(mm)	Range(m/s)	Accuracy
3 ~ 20	≤ 0.3	$\pm 0.25\%FS$
	0.3~1	$\pm 1.0R$
	1~15	$\pm 0.5\%R$
25 ~ 600	0.1~0.3	$\pm 0.25\%FS$
	0.3~1	$\pm 0.5\%R$
	1~15	$\pm 0.3\%R$
700~3000	≤ 0.3	$\pm 0.25\%FS$
	0.3~1	$\pm 1.0\%R$
	1~15	$\pm 0.5\%R$
%FS: for relative ranges;		
%R: for relative value of measurement		

Simulated current output

Load resistor: 0~750 Ω (4~20mA). Basic Errors: 0.1% \pm 10 μ A.

Digital frequency output

Frequency output range: 1 ~ 5000Hz;

Output electric isolate: Photoelectric isolate. Isolate voltage: > 1000VDC;

Frequency output drive: output by field-effect transistors, the highest subjected voltage is 36VDC, maximum of output current is 250mA.

Digital pulse output

Pulse output range: 0 ~ 100 pulse/s. (When higher than upper limit, pulse will lose); Pulse output value: 0.001 ~ 1.000m3 / cp 0.001 ~ 1.000 Ltr / cp 0.001 ~ 1.000USG / cp, 0.001 ~ 1.000UKG / cp;

Pulse output width: 50ms,

Pulse output isolate: photo electricity isolate. Isolate voltage: > 1000VDC;

Pulse output drive: output by field-effect transistors, the highest subjected voltage is 36VDC, maximum of output current is 250mA.

Alarm output

Alarm output junction:ALMH--- upper limit; ALML--- lower limit; Output isolate: photo electricity isolate. Isolate voltage: > 1000VDC;

Alarm output drive: output by Darlington pipe, the highest subjected voltage is 36VDC, maximum of output current is 250mA.

Digital communication port and protocol MODBUS interface: format of RTU.

Analog Loop Communication interface: designed by standard of Analog Loop Communication, if you choose our hand held unit, you can display the measure value on line, and setting the parameters.

Electric isolate

Insulated voltage between simulated input and simulated output should be higher than 500V; Insulated voltage between simulated input and alarm power supply should be higher than 500V; Insulated voltage between simulated input and AC power supply should be higher than 500V; Insulated voltage between simulated output and AC power supply should be higher than 500V; Insulated voltage between simulated output and earth should be higher than 500V;

Insulated voltage between pulse output and AC power supply should be higher than 500V; Insulated voltage between pulse output and earth should be higher than 500V;

Insulated voltage between alarm output and AC power supply should be higher than 500V; Insulated voltage between alarm output and earth should be higher than 500V;

Key and display

Squared define keys and LCD screen display

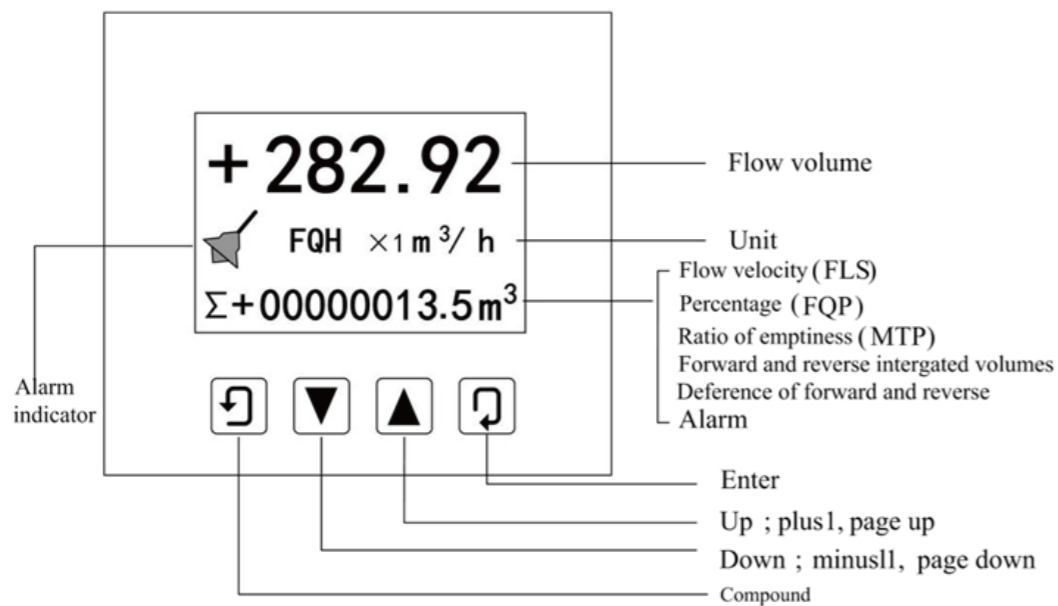

Fig. 4.1 (c) Keys on squared panel and large LCD display:

Rotundity define keys and LCD screen display

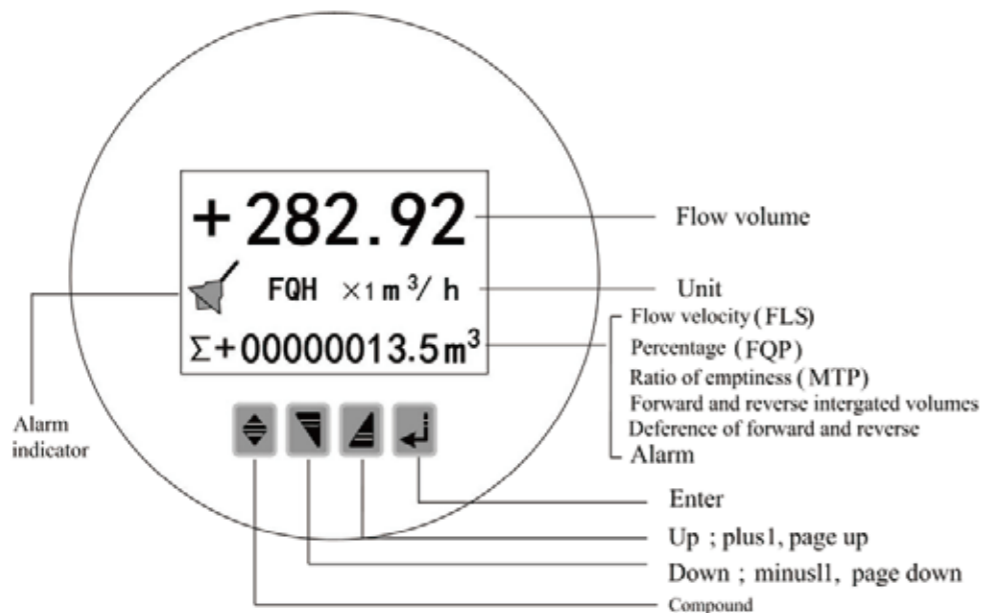

Fig. 4.1(d) Keys on Circular panel and big LCD display

Note: When measuring, pushing down “Compound Key + Enter” will appear password of changing state, base on distinction of secrecy, and change the password as we provide. Then pushing “Compound Key + Enter” again, and you can inter the state of setting parameter. If want to return to the running state, push “Enter” for several seconds.

Section picture of conversion



Fig.4.2 (c) L-mag 211B-4 Key



Fig.4.2 (d) L-mag 411B-4 Key

Connections of sensor

Connectors and labels for the squared

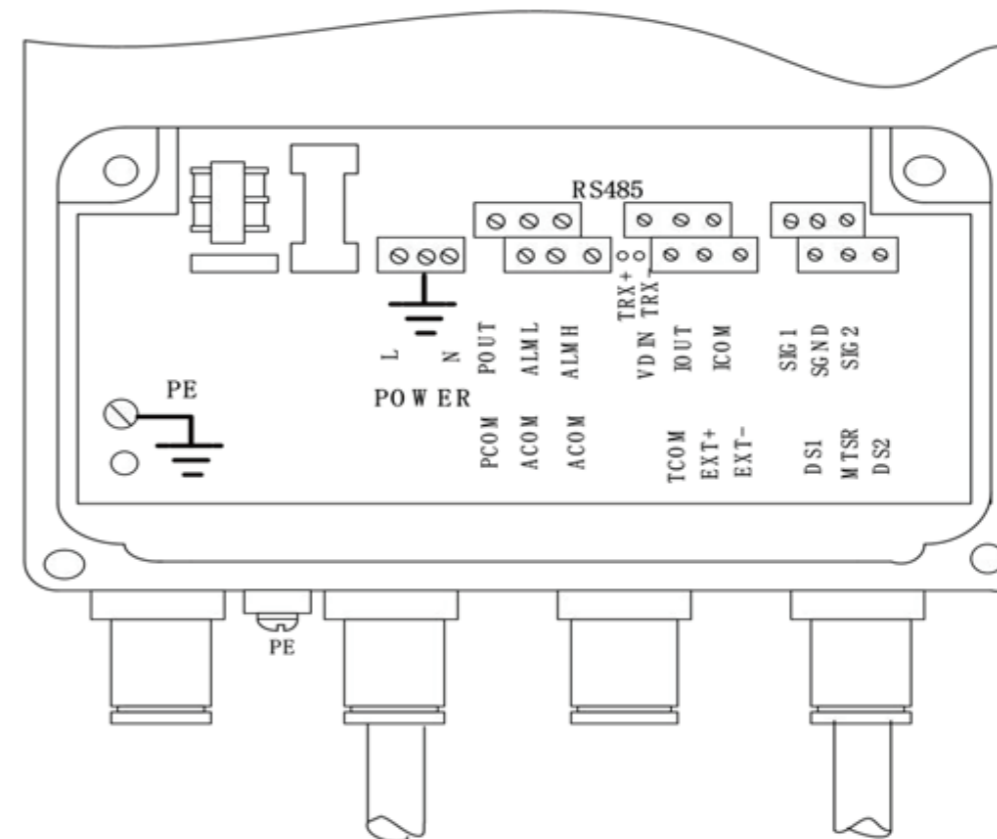
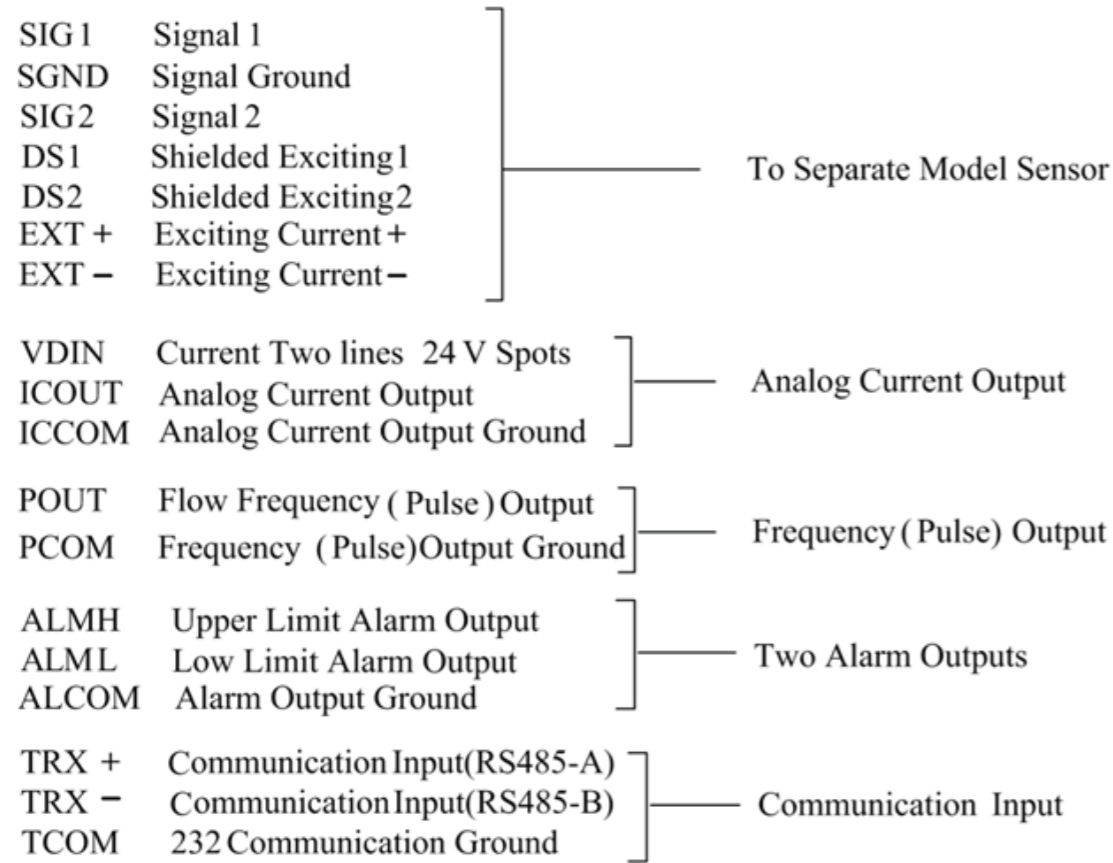

Fig.4.3 (a) Connectors for 211B

Labels of connectors in squared model



Links and labels of connectors in Circular Model

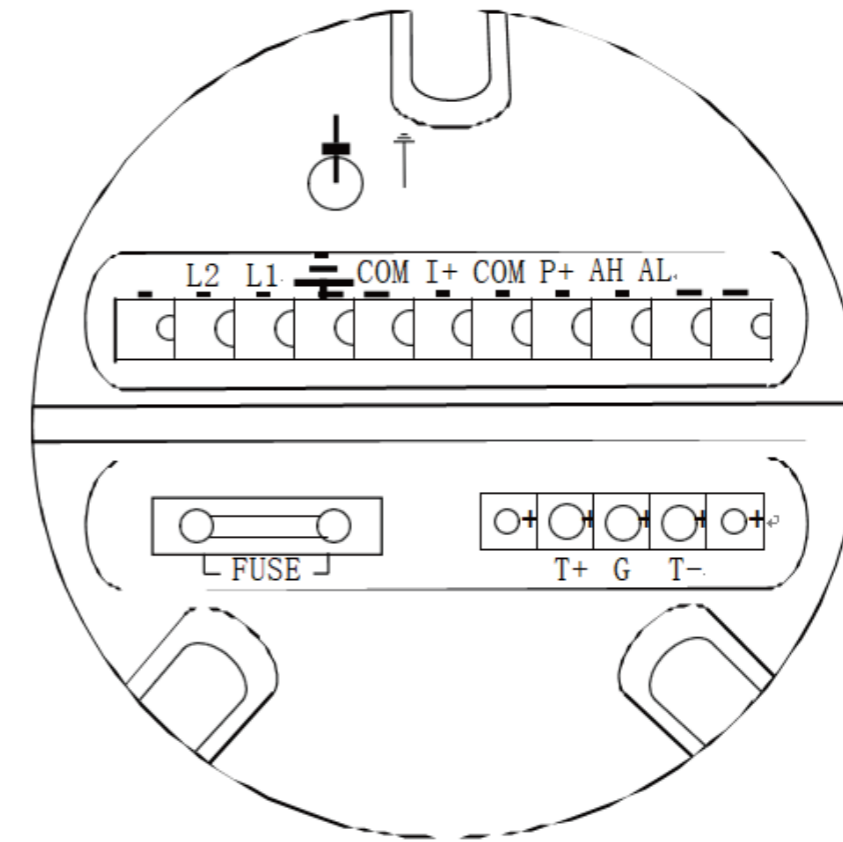

Fig.4.3(c) Connectors in circular model

Signal lines and labels in squared model

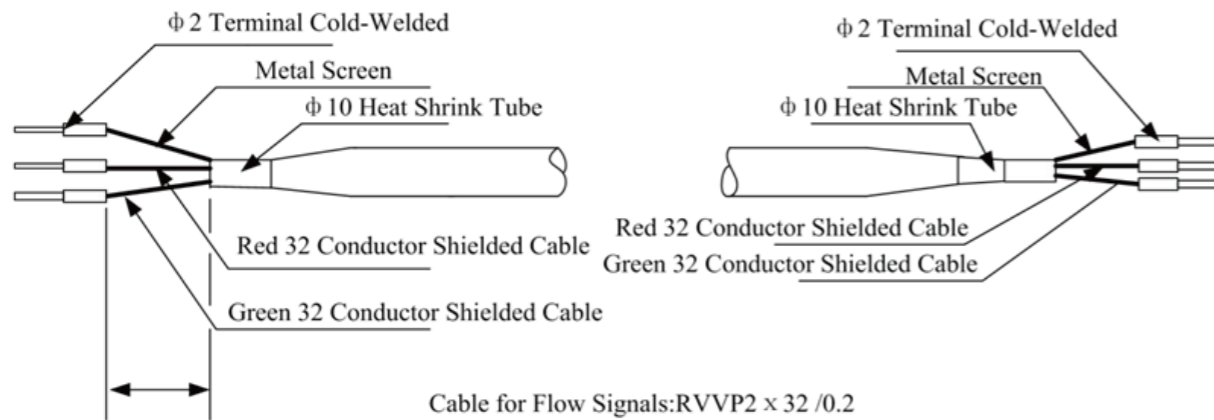

Fig.4.3 (b) Connection and labels of signal lines in squared model

Symbols and Description of Connectors in Circular Pane

I+:	Output Current for Flow Measurement
COM:	Output Current (Ground) for Flow Measurement
P+:	Frequency(Pulse) Output for Bi-directional Flow
COM:	Frequency (Pulse) Output (Ground)
AL:	Alarm Output for Low Limit
AH:	Alarm Output for Upper Limit
COM:	Alarm Output (Ground)
FUSE:	Fuse for Power Supply
T+:	+Communication Input Signal(RS485-A)
T-:	-Communication Input Signal(RS485-B)
G	RS232 Communication Ground
L ₁ :	220V (24V) Power Supply
L ₂ :	220V (24V) Power Supply

Labels and connection of signal lines in Circular model

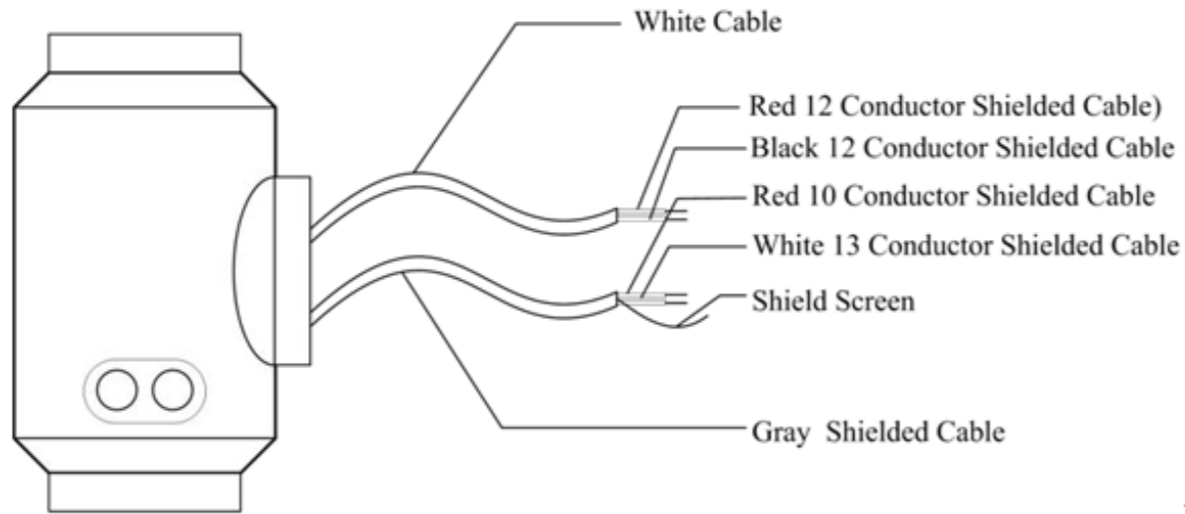

Fig.4.3 (d) Labels and connection of signal lines in Circular model

Signal lines labels in Circular model:

White twisted-pair cable (for exciting current): 12 Conductors (Red)
12 Conductors (Black)

Gray shielded twisted-pair cable: 10 Conductors (Red) connected to "Signals 1"

13 Conductors (White) connected to "Signals 2" Shielded Conductor connected to "Signal Ground"

Characteristic and connection of cable

Flux signal line

When separated models of converters are assembled with sensors for measuring flow of fluid which conductivity is larger than $15\mu\text{S}/\text{cm}$, PVVP 2*0.2 mm² model cable (metal shielded signal cable covered with PVC) can be used as communication cable for flow signals. The length of signal cable should be less than 100m. Signal cables have to be connected to sensors that were assembled by producers.

Connections of signal cables are shown in Fig. 4.3(b) for squire-shaped models and Fig. 4.3(d) for circle- shaped models, respectively.

The converter can output equivalent level of shielded exciting signal voltage so that interference to flow measurement signals can reduced by means of lowering the distributed capacitance of communication cable. When measured conductivity is less than $15\mu\text{S}/\text{cm}$ or signals are transferred in remote distances, double-conductor and double-shielded signal cable at equivalent level of voltage can be used. For example, special STT3200 cable or BTS model signal cable (triple-shielded) can be used for signal communication.

Exciting current cable

Two conductor and insulating rubber- covered cables can be used as exciting current cables. Suggested model is RVVP2*0.3 mm². Length of exciting current cable should be equal to that of signal cable. When the model STT3200 cables are used for exciting current and signals, two cables can be put together as one cable.

Output and power line

All cables for signals transferring and power supply must be prepared by users. However, it should be careful to choose the cables that meet the upper limit load of consuming current.

Note: When DIP switch next to terminal is set to ON places, the converter from its inside can provide +28V power supply and up-pull 10k Ω resistance to output Frequencies (PUL) to isolated OC gate, Alarm Output (ALMH.ALML), and Status Control (INSW).Therefore, when converter has frequency output and works with sensor together, DIP switch can be set as ON getting frequency signals from POUT and PCOM terminals. Pulse current output, alarm current output and external power supply can be seen in Fig.4.4(a). When inductive load is connected to converter, diode should be used as in Fig.4.4(b).

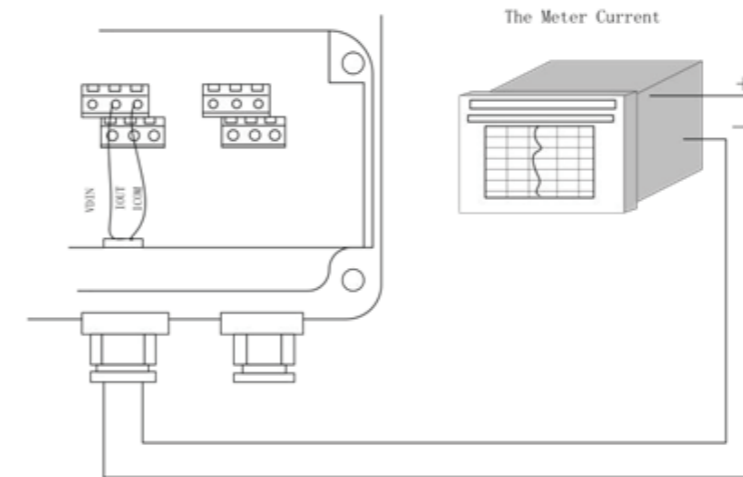

Fig.4.4 (a) Output current circuit

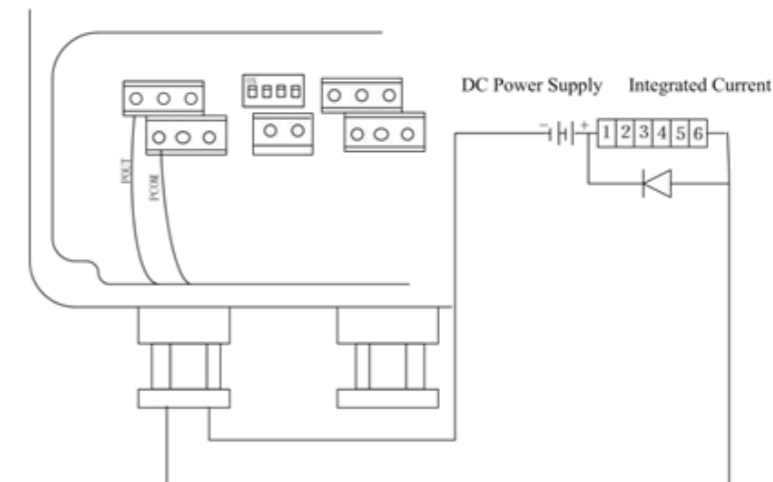

Fig.4.4 (b) Connection of electro-magnet counter

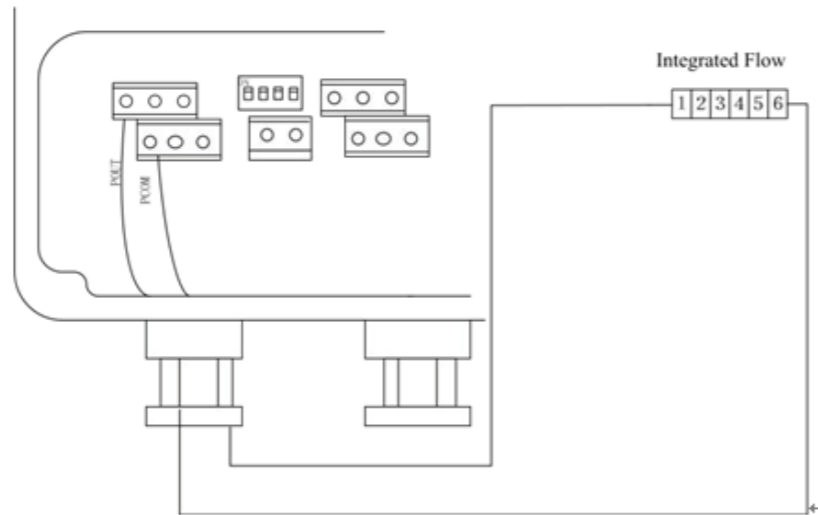

Fig.4.4 (c) Connection of electronic counter

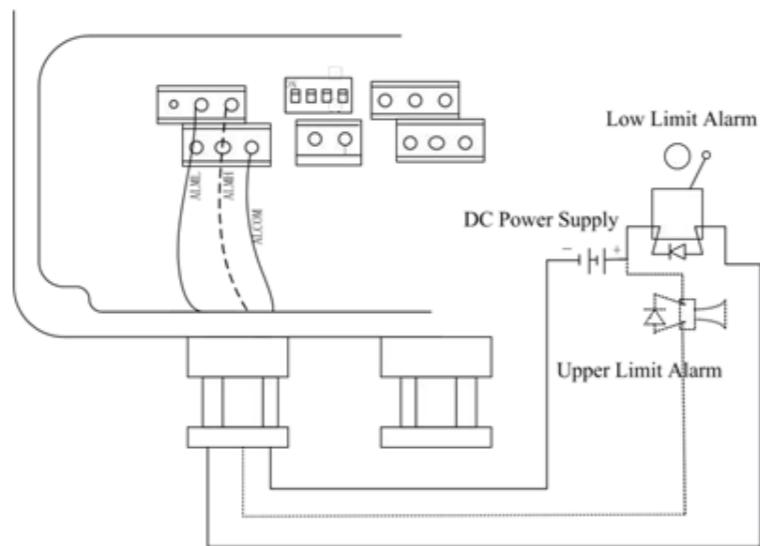

Fig.4.4 (d) Connection of alarm output

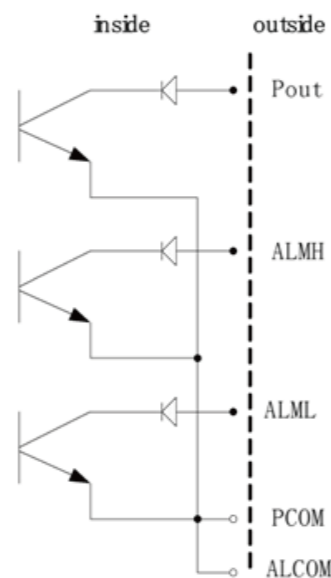

Fig.4.4 (e) Connection of OC gate

The grounding requirements when installing convert

Contact area of copper Connector PE on Converter Cabinet for grounding should be larger than 1.6mm². Contact resistance should be less than 10Ω.

First, purple copper tube should be cut into 1700 mm long (the copper tube can be lengthened according to the need) to make the nail buried 1500 mm into the ground (Note : when burying nail, sprinkling a layer of broken charcoal at the top of nail, and then saline irrigation).

Then, 4 mm² purple copper wire should be welded to the nail. At last, connecting ground wire to convert's flange, ground ring and pipeline's flange. It is shown in figure 4.4 (f)

Note: Stainless steel must be used when fixing ground screws, spring washers and flat washers.

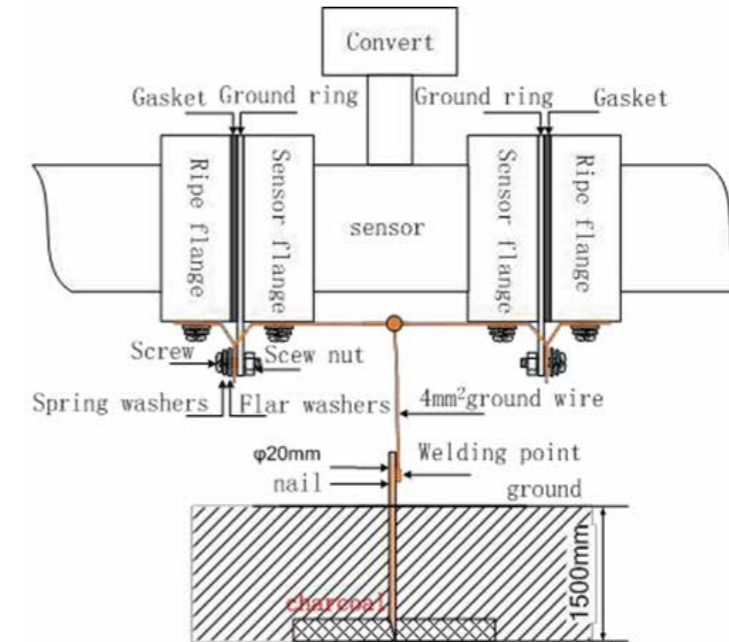

Fig.4.4(f) Grounding

Digital output and calculate

Digital output means frequency output and pulse output, and both of them use the same output point, so user can choose only one type of them but not both.

Frequency output

Frequency output range is 0 ~ 5000HZ, and corresponding the percent of flux.

$$F = \frac{\text{Measure value}}{\text{Full scale value}} \bullet \text{frequency range}$$

The up limit of frequency output can be adjusted. It can be chosen from 0 ~ 5000HZ, and also can be chosen low frequency: such as 0 ~ 1000HZ or 0 ~ 5000HZ.

Frequency output mode general can be used in control application, because it responses the percent flux. Users can choose pulse output when the equipment is applied to count.

Pulse output mode:

Pulse output mainly applies in count mode. A pulse output delegates a unit flux, such as 1L or 1M3 etc. Pulse output unit divide into 0.001L, 0.01L, 0.1L, 1L, 0.001m3, 0.01m3, 0.1m3, 1m3 ,0.001UKG,0.01UKG, 0.1UKG,1UKG,0.001USG,0.01USG,0.1USG,1USG .When users choose the pulse unit, they should notice the match of the flux range of flow meter and pulse unit. For volume flux, count formula as follows:

$QL=0.0007854 \times D^2 \times V$ (L/S)
 Or $QM=0.0007854 \times D^2 \times V \times 10^{-3}$ (M3/S)

Note: D-nozzle (mm)
 V-velocity of flow (m/s)

The oversize flux and too small pulse unit will be made the pulse output over the up limit. Generally, pulse output should be controlled below 3000P/S. However, the too small flux and too large pulse unit will be made the instrument exports a pulse long time.

Otherwise, pulse output is different from frequency output. When pulse output cumulates a pulse unit, it exports a pulse. Therefore, pulse output is not equality. Generally, measure pulse output should choose to count instrument, but not frequent instrument.

The connection of digital output

Digital output has tow connected points: digital output connected point, digital ground point, and symbol as follows:

POUT digital output point;
 PCOM digital ground point

POUT is collector plough output, user may refer to next circuit to connect.

The connection of digital voltage output

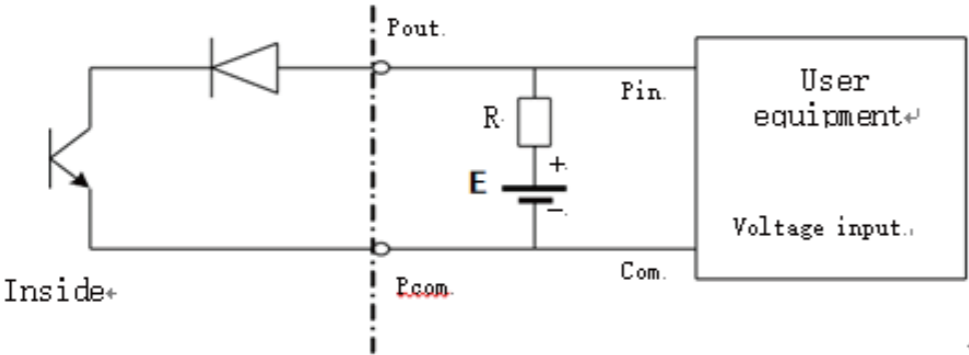

Fig.4.5(a) The connection of digital voltage output

Digital output connect photoelectricity coupling (PLC etc.)

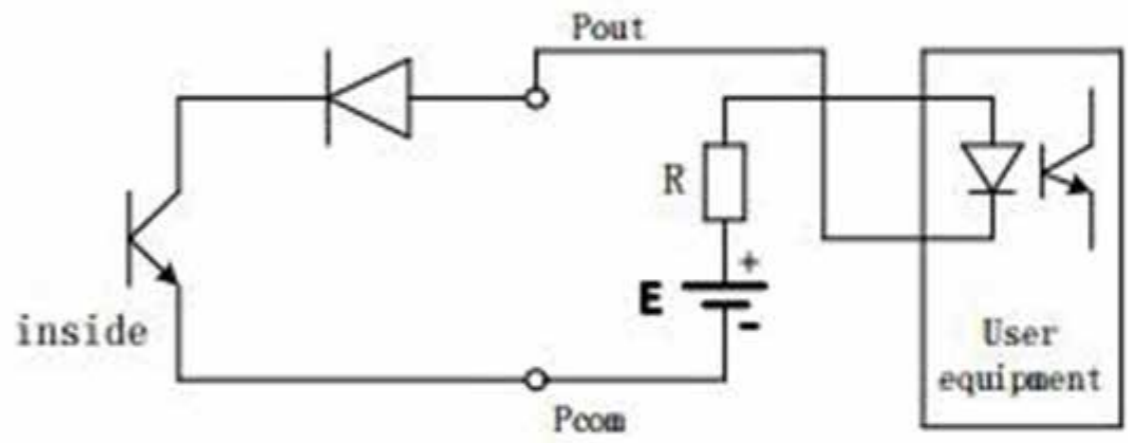

Fig.4.5(b) Digital output connect photoelectricity coupling

Commonly user's photoelectricity coupling current is about 10mA, so about $E/R=10mA$, $E=5 \sim 24V$.

Digital output connect relay

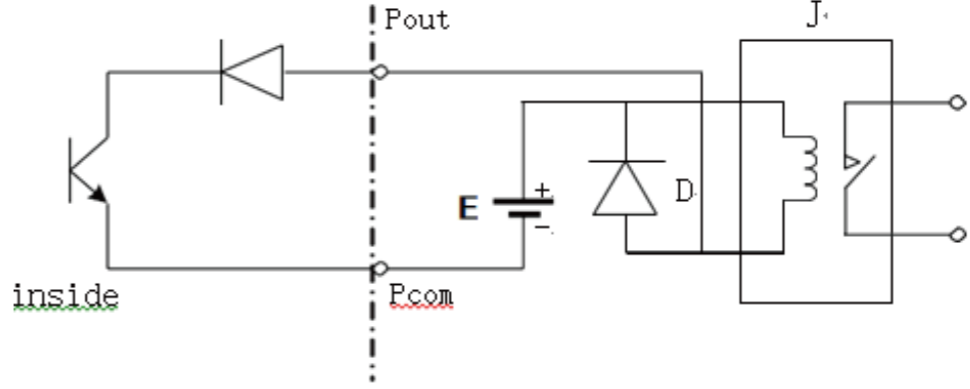

Fig.4.5 (c) Digital output connect relay

Commonly relay needs E as 12V or 24V. D is extend diode, now most middle relays has this diode inside. I f not have, user can connect one outside.

Table of digital output parameter:

POUT					
Parameter	Test condition	Mini	Typical	Max	Unit
Voltage	$I_C=100\text{ mA}$	3	24	36	V
Current	$V_{ol} \leq 1.4V$	0	300	350	mA
Frequency	$I_C=100mA$ $V_{cc}=24V$	0	5000	750 0	HZ
High voltage	$I_C=100mA$	V_{cc}	V_{cc}	V_{cc}	V
Low voltage	$I_C=100mA$	0.9	1.0	1.4	V

Simulation signal output and calculate

Simulation signal output

Simulation signal output inner is 24V under 4~20mA, it can drive 750Ω resistance. The percent flux of simulation signal output:

$$I_0 = \frac{\text{Measure value}}{\text{Full scale value}} \bullet \text{the scale of current} + \text{the zero point of current}$$

The current zero is 4mA when 4~20mA.

It can be advanced simulation signal output distinguish. User can select the range of measure.

The manufacture's parameter have been adjusted, it don't need adjust. If have abnormality, it can consult 4.6.2.

Simulation Signal Output Adjust

(1)The Converter adjust preparative

When the converter is running 15 minutes, the inner of converter becomes stabilization.

Preparative 0.1% ammeter or 250Ω , 0.1% voltage instrument.

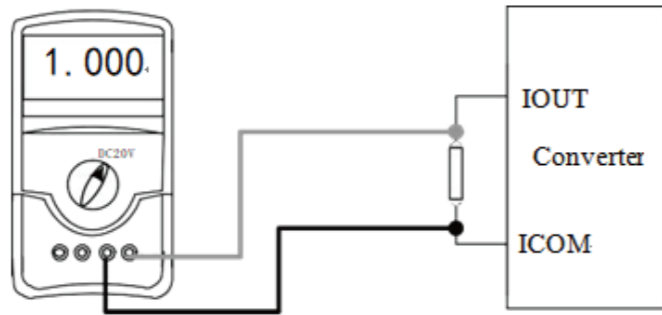

(2)Current zero correct

When the converter getting into parameter setting, selecting to "Analog Zero" and enter to it. The standard of signal fountain getting to "0". Adjust the converter parameters to make the ammeter display 4mA (±0.004mA)

(3)The full scale current correct

Select "Anlg Range" and enter. Adjust the converter parameters to make the ammeter display 20mA (±0.004mA) Adjust the current zero and the full range, the current function of the converter reached exactness.

The line degree of current output of conversion should be controlled within the scope of 0.1%

(4)Current line degree checking

You can place the standard signal source in 75%,50%,25%,and check the line degree of current output.

Electromagnetic flow meter converter's connection of current output:

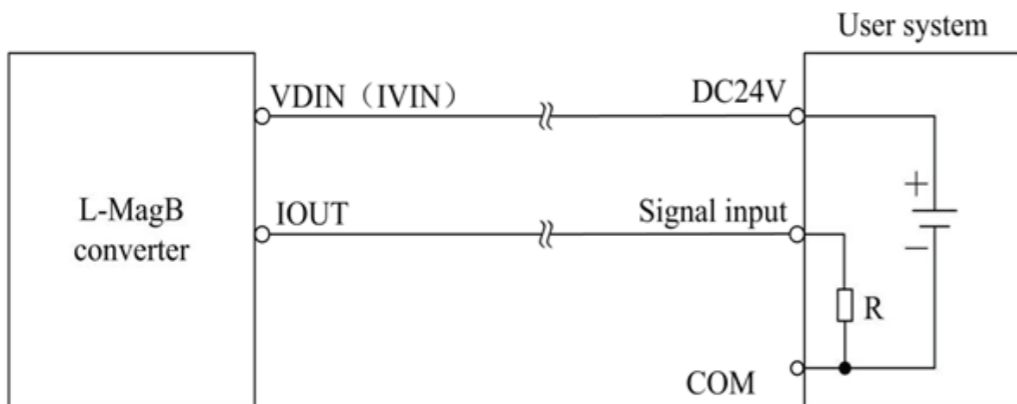

Fig.4.6 (a) L_MagB two connection

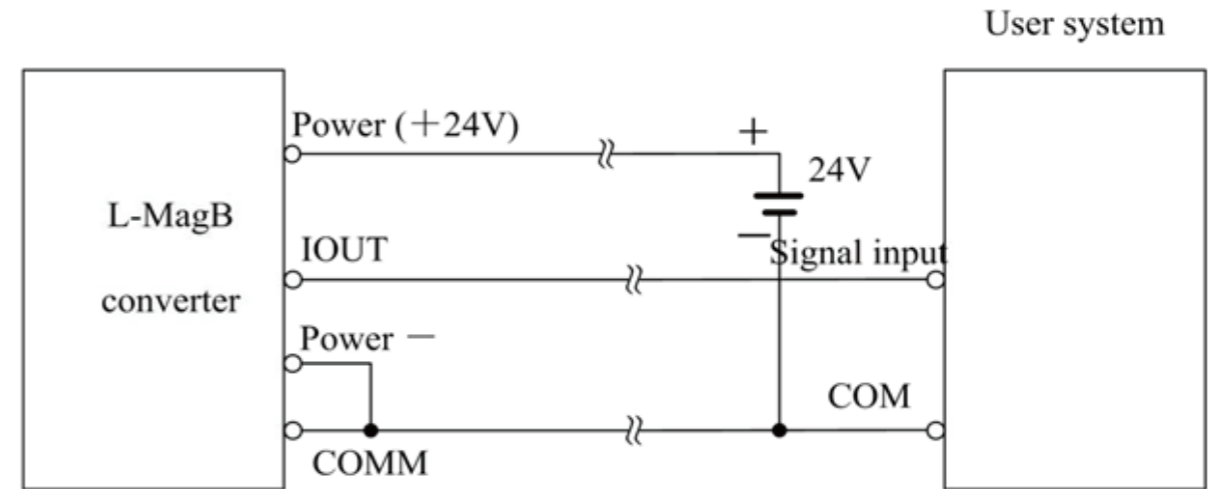

Fig.4.6 (b) L_MagB three connection(power supply and current output are not insulated)

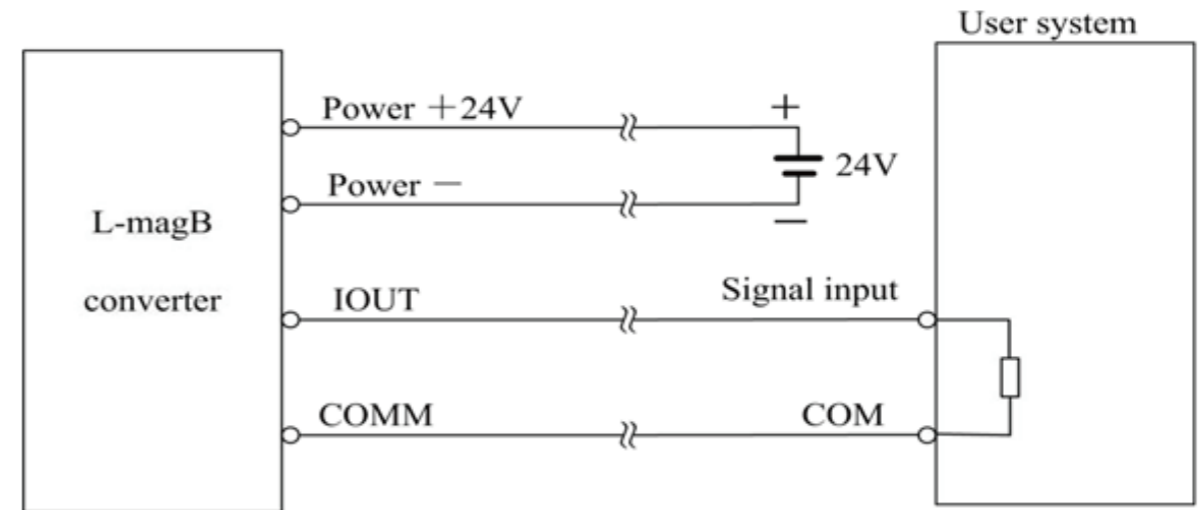

Fig.4.6 (c) L-magB four connection(power supply and current output are insulated)

After electromagnetic flow meter converter and sensor connect to the pipe (no matter demarcate or use), may do the next work first:

- Connect the pipe fore-and-aft the sensors tighten.
- Make sure the sensor connects the earth.
- Make sure the liquid stillness when regulating zero of the instrument.
- Make sure the oxidation velum of sensor makes steadily (electrode and liquid contact continuously about 48 hours).

Parameters and setting

When electrify, the instrument comes into measure way automatically, and under this way it can do all the functions and display data. Under the parameter setting way, user can set the parameter by the four keys.

Keys function

(a) Keys' function in self- testing way

“Down” key: Selecting displayed data on lower line in turn; “Up” key: Selecting displayed data on higher line in turn; “Compound” key + “Enter” key: Come into parameter setting “Enter” key: Press it to come into the picture of select function.

Under the measure, adjust of the LCD contract is used “Compound” key + “Up” key or “Compound” key + “Down” key for several seconds;

(b) Function keys for parameters setting

“Down” key: Subtract 1 from the number at cursor area; “Up” key: Plus 1 to the number at cursor area; “Compound” key + “Down” key: Cursor turns left;

“Compound” key + “Up” key: Cursor turns right; “Enter” key: In/Out submenu; “Enter” key: Press for two seconds under any state and will return to automate measure way. Note:

- (1) When use “Compound” key, you should press “Compound” key and “Up” or “Down” both;
- (2) It will return to the measure way automatically after 3 minutes when under the parameter setting way;
- (3) Direct select of zero correction about the flow, you can move the cursor to the left + or - , and use “Down” or “Up” to switch;

Function keys for setting parameters

To set or correct working parameters, the converter should be running in parameters setting way instead of measuring status. In measuring status, push “Compound”+“Enter” keys getting to the select of parameter and transfer password (0000), and then correct the password with one of the new passwords that are provided by manufacturer. Finally, push the “Compound”+“Enter” keys to work in Parameters Setting Way. There are 6 Passwords in design and among them 4 for deferent operators in secret and 2 are fixed passwords for system operation.

Functions select menu

Push “Compound”+“Enter” keys to the functions select menu, push “Up” or “Down” keys to select, there are three functions:

Code	Functions	Notes
1	Parameters Set	Select this function; It can enter the picture of parameter.
2	Clr Total Rec	Select this function,It can be gross reset operation.
3	Fact Modif Rec	Select this function, It can be check the factor 's modif Record

Parameters Set

Press “Compound”+“Enter” key, it displays “Parameters Set” function. Input password. Press “Compound”+“Enter” key, it getting to Parameters Setting status.

Clr Total Rec

To push “Compound”+“Enter” keys getting to the select of parameter, then push “Up” key to “Clr Total Rec”, input the passwords. When the passwords becomes “00000”, this function is done, the gross is 0 in the instrument.

Fact Modif Rec

To push “Compound”+“Enter” keys getting to the select of parameter, then push “Up” key to “Fact Modif Rec”(Detail consult the AppendixFive)

Setting Parameters in Menu

There are 55 parameters of , user can set every parameter. The List of Parameters is shown below:

Setting Parameters in Menu

Code	Parameter words	Setting Way	Grades	Range
1	Language	Select	2	English
2	Comm Addres	Set count	2	0~99
3	Baud Rate	Select	2	300~38400
4	Snsr Size	Select	2	3~3000
5	Flow Unit	Select	2	L/h,L/m,L/s,m3/h, m3/m,m3/s ,UKG,USG
6	Flow Range	Set count	2	0~99999
7	Flow Rspns	Select	2	1~50
8	Flow Direct	Select	2	Plus/ Reverse
9	Flow Zero	Set count	2	0~±9999
10	Flow Cutoff	Set count	2	0~599.99%
11	Cutoff Ena	Select	2	Enable/Disable
12	Total Unit	Select	2	0.001m3~1m3 , 0.001L~1L, 0.001UKG ~ 1UKG, 0.001USG~1USG,
13	SegmaN Ena	Select	2	Enable/Disable
14	Analog Type	Select	2	4~20mA/4mA
15	Pulse Type	Select	2	Freque / Pulse
16	Pulse Fact	Select	2	0.001m3~1m3 , 0.001L~1L, 0.001UKG ~ 1UKG, 0.001USG~1USG,
17	Freque Max	Select	2	1~ 5999 HZ
18	Mtsnsr Ena	Select	2	Enable/Disable
19	Mtsnsr Trip	Set count	2	59999 %
20	Alm Hi Ena	Select	2	Enable/Disable

21	Alm Hi Val	Set count	2	000.0~ 599.99 %
22	Alm Lo Ena	Select	2	Enable/Disable
23	Alm Lo Val	Set count	2	000.0~599.99 %
24	Sys Alm Ena	Select	2	Enable/Disable
25	Clr Sum Key	Set count	3	0~99999
26	Snsr Code1	User set	4	Finished Y M
27	Snsr Code2	User set	4	Product number
28	Field Type	Select	4	Type1,2,3
29	Sensor Fact	Set count	4	0.0000~5.9999
30	Line CRC Ena	Select	2	Enable/Disable
31	Lineary CRC1	User set	4	Set Velocity
32	Lineary Fact 1	User set	4	0.0000~1.9999
33	Lineary CRC2	User set	4	Set Velocity
34	Lineary Fact 2	User set	4	0.0000~1.9999
35	Lineary CRC3	User set	4	Set Velocity
36	Lineary Fact 3	User set	4	0.0000~1.9999
37	Lineary CRC4	User set	4	Set Velocity
38	Lineary Fact4	User set	4	0.0000~1.9999
39	FwdTotal Lo	Correctable	5	00000~99999
40	FwdTotal Hi	Correctable	5	00000~9999
41	RevTotal Lo	Correctable	5	00000~99999
42	RevTotal Hi	Correctable	5	00000~9999
43	PlsntLmtEna	Select	3	Enable/Disable
44	PlsntLmtVal	Select	3	0.010~0.800m/s
45	Plsnt Delay	Select	3	400~2500ms
46	Pass Word 1	User correct	5	00000~99999
47	Pass Word 2	User correct	5	00000~99999
48	Pass Word 3	User correct	5	00000~99999

49	Pass Word 4	User correct	5	00000~99999
50	Analog Zero	Set count	5	0.0000~1.9999
51	Anlg Range	Set count	5	0.0000~3.9999
52	Meter Fact	Set count	5	0.0000~5.9999
53	Meter Code 1	Factory set	6	Finished Y /M
54	Meter Code 2	Factory set	6	Product Serial No
55	Check Mode	Select	2	No Parity/Odd Parity/Even Parity

Parameters of converters can decide the running status, process and output ways as well as state of output. Correct option and setting of parameters can keep the converters running optimally and get higher accuracies of output both in display and in measurement.

There are 6 grades of passwords for setting parameters function. Grades 1 to grade 5 of passwords are for users and grade 6 of password is for manufacturer. Users can reset their passwords of grades 1~4 in grade 5.

Users can check converters parameters in any grade of password. However, if users want to change parameters of converters, different grade of parameters have to be used by the users.

Grade 1 of password (set by manufacturer as 00521): users can only read parameter. Grade 2 of password (set by manufacturer as 03210): users can change 1~24 parameters. Grade 3 of password (set by manufacturer as 06108): users can change 1~25 parameters. Grade 4 of password (Fixed): users can change 1~52 parameters.

Password Grade 4 can be set by skilled users. Grades 1~3 can be set by anyone who can be chosen by users.

Details Parameters

Language

There are 2 languages for converter operation. They can be set by users according to the users needs.

Comm Address

It means this instrument's address when communicates with many, and has 01~99, holding the 0.

Baud Rate

300, 1200, 2400, 4800, 9600, 38400, baud rate.

Check Mode

The standard MODBUS communication for is 8 bit No Parity, users can choose 8 bit odd parity and 8 bit even parity according to the need.

Snsr Size

Converters can be equipped with some different sensors that have different diameter of measuring pipes. The pipes in different diameters from 3mm to 3000mm can be chosen in relative table.

Flow unit

The flow unit can choose from the parameters (L/h,L/m,L/s,m³/h,m³/m,m³/s,UKG,USG),and the user can choose the proper unit according to the technological requirement and using habit.

Flow Range

Flow range means upper limit value, and lower limit value is set "0" automatically. So, it makes the range, and makes the relation of percent display, frequency output and current output with flow:

percent display = (flow measure / measure range) * 100 %;

frequency output = (flow measure / measure range) * frequency full;

current output = (flow measure / measure range) * current full + base point; pulse output will not affect.

Flow Rspns

It means time of filter measure value. The long one can enhance the stability of flow display and output digital, and fits for gross add up of pulse flow; the short one means fast respond rate, and fits for production control. It is set by select.

Flow Direct

If users think the direct and design are differ, just change the direct parameter is OK, but not change exciting or signal.

Flow zero

Make sure the sensor is full of flow, and the flow is stillness. Flow zero is shown as velocity of flow, mm/s.

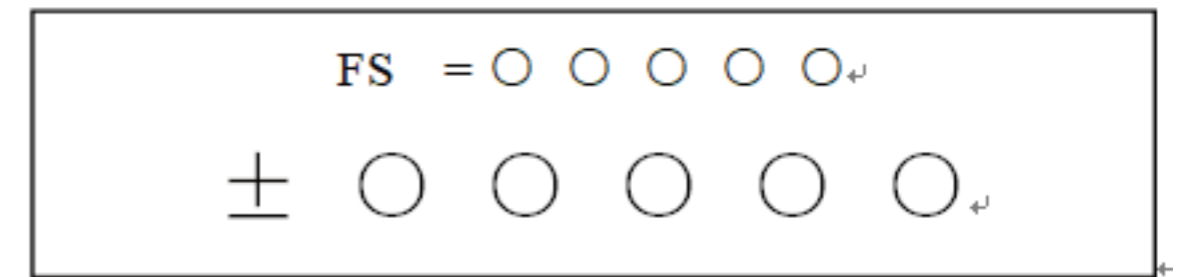

Converter's zero-flow correction displays like this: Upper small words: FS means measure value of zero; Lower large words: correction value of zero.

When FS is not "0", make FS = 0. Note: if change the value on next line and FS increases, please change the "+, -" to correct FS to zero.

Flow zero is the compound value of the sensor, and should be recorded in sensor list and band. The unit will be mm/s, and the sign will be opposite with correction value.

Flow cutoff

Flow cutoff is set in percentage of Upper Limit Range of flow, and users can delete all Negligible Small Signals of flow volume, velocity and percentage out of displaying and outputting them. Sometimes user can delete output of current output signal and frequency (pulse) output signal only to have flow, velocity and percentage being displayed.

Total Unit

Converter display is counter with 9 bits, and the max is 999999999. Integrator units are L, m3 (liter, cubic meter).

Flow integrator value:

- 0.001L,0.010L,0.100L,1.000L
- 0.001m3,0.010m3,0.100m3,1.000m3 ;
- 0.001UKG,0.010UKG,0.100UKG,1.000UKG,
- 0.001USG,0.010USG, 0.100USG,1.000USG.

SegmaN Ena

When “SegmaN Ena” is “enable”, if the flow flows, the sensor will export pulse and current . When it is “disable”, the sensor will export pulse as “0” and current as “0”(4mA or 0mA) for the flow flows reversals.

Analog Type

4~20mA practically.

Pulse Type

Two kinds of Pulse Outputs are can be chosen: Frequency Output and Pulse Output. Frequency Output is continuous square waveform and Pulse output is a serial wave of square wave. Frequency output is mainly used for instant flow and total integrated flow in short time measurement. Frequency output can be chosen in equivalent frequency unit and volume of integrated flow can be displayed. Frequency Output can be used in long time measurement for total integrated flow with volume units.

Frequency output and pulse output are usually from OC gates so that DC power supplies and load resistors have to be required (See Part 4.5).

Pulse Fact

Equivalent pulse Unit is referred to one pulse for value of flow. The range of pulse equivalent can be chosen:

Pulse Equivalent	Flow	Pulse Equivalent	Flow
1	0.001L/cp	9	0.001USG/cp
2	0.01L/cp	10	0.01 USG /cp
3	0.1L/cp	11	0.1 USG /cp
4	1.0L/cp	12	1.0 USG /cp
5	0.001m ³ /cp	13	0.001UKG/cp
6	0.01m ³ /cp	14	0.01 UKG /cp
7	0.1m ³ /cp	15	0.1 UKG /cp
8	1.0m ³ /cp	16	1.0 UKG /cp

Under the same flow, the smaller pulse, the higher frequency output, and the smaller error will be. The highest pulse output is 100cp/s, and mechanism electromagnetic counter can get 25 frequency/s.

Freque Max

Frequency output range is as the upper limit of flow measure, just the percent flow 100%. Frequency output upper limit can be selected between 1 ~ 5000Hz.

The state of empty pipe can be detected with the function of converter. In the case of Empty Pipe Alarm, if the pipe was empty, the signals of analog output and digital output would be zero and displayed flow would be zero, too.

Mtsnsr Ena

The state of empty pipe can be detected with the function of converter. In the case of Empty Pipe Alarm, if the pipe was empty, the signals of analog output and digital output would be zero and displayed flow would be zero, too.

Mtsnsr Trip

When the pipe is full of liquid (whether flowing or not), the parameter of “Mtsnsr” could be modified more easily. The parameter displayed upper line is real MTP, and the parameter displayed bellow is the “Mtsnsr trip” that should be set. When setting “Mtsnsr trip”, you could be according to the real MTP, the value that should be set is usually three to five times of real MTP.

Alm Hi Ena

Users can choose “Enable” or “Disable”.

Alm Hi Val

The parameter of upper limit alarm is percentage of flow range and can be set in the way of setting one numerical value between 0%~199.9%.When the value of flow percentage is larger than the value of setting value, the converter outputs the alarm signal.

Alm Lo Val

The same as upper limit alarm.

Sys Alm Ena

Selecting Enable will have the function, and selecting Disable will cancel the function.

Clr Sum Key

User use more than 3 byte code to enter ,Then set this password in Clr Total Rec.

Snsr Code

It is referred to the produced date of sensor and the serial number of product that can keep the sensors coefficient right and accurate.

Sensor Fact

“Sensor Coefficient” is printed on the Label of the sensor when it is made in factory. The “sensor coefficient” has to be set into Sensor Coefficient Parameter when it runs with converter.

Field Type

affords three exciting frequency types: 1/16 frequency (type 1), 1/20frequency (type 2), 1/25 frequency (type 3). The small-bore one should use 1/16 frequency, and large-bore one should use 1/20 or 1/25 frequency. When using, please select type 1 first, if the zero of velocity is too high, select the type 2 or type 3.

Note: Demarcate on which exciting type, working on it only.

FwdTotal Lo,hi

Positive total volume high byte and low byte can change forthcoming and reverse total value, and be used to maintenance and instead.

User use 5 byte code to enter, and can modify the positive accumulating volume ($\Sigma+$). Usually, it is unsuitable to exceed the maximum the counter set (999999999) .

RevTotal Lo,hi

User use 5 byte code to enter, and can modify the negative accumulating volume ($\Sigma-$). Usually, it is unsuitable to exceed the minimum the counter set (999999999)

PlsntLmtEn

For paper pulp, slurry and other serosity, the flow measure will have "cuspidal disturb", because the solid grain friction or concussion the measure electrode. converters use variation restrain arithmetic to conquer the disturbing by designing three parameters to select disturb character.

Set it "enable", start variation restrain arithmetic; set it "disable", close variation restrain arithmetic.

PlsntLmtVI

This coefficient can disturb the variation of cuspidal disturb, and calculate as percent of flow velocity, thus ten grades: 0.010m/s, 0.020m/s, 0.030m/s, 0.050m/s, 0.080m/s, 0.100m/s, 0.200m/s, 0.300m/s, 0.500m/s, 0.800m/s, and the smaller percent, the higher delicacy of cuspidal restrain.

Note: when using it, must test for select by the fact, and sometimes it is not the higher delicacy is good.

Plsnt Delay

This coefficient can select the width of time of restrain cuspidal disturb and the unit is ms. If the duration is shorter than flow change in some time, will think it is cuspidal disturb, and if it is longer, will think it is natural. It also needs to select parameter in fact.

User's password 1~4

Users can use 5 grades of passwords to correct these passwords.

Analog Zero

When the converters are made in the factory, output current has been calibrated to zero scale, that is, accurate 0mA or 4mA output.

Anlg Range

When the converters is made in the factory, output current have been calibrated to full scale, that is, accurate 10mA or 20mA output.

Meter Fact

This fact is the special one of sensor-made-factory and the factory use this fact to unite electromagnetic flow meters converters to make sure all the instruments can interchange by 0.1%.

Meter Code 1 and 2

Converter code records the date of manufacturing and serial number of converter.

Infrared remote control function keys

The operation of the infrared-hand-remote control keyboard is the same with the operation of the instrument. When use it, please keep the infrared transmitter of the infrared-hand-remote control keyboard and the receiver of the instrument parallel, with the distance of about one meter.

Concrete operation referring to the figure:

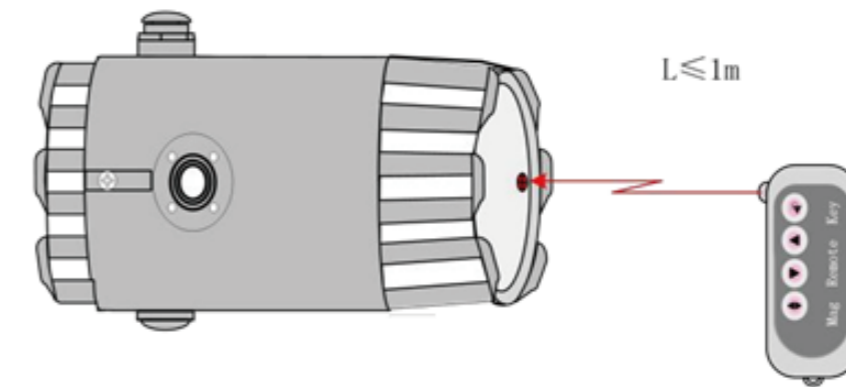



Fig 6.1: The communication figure of the infrared-hand-remote control keyboard and the instrument

Alarm information

PCB of electromagnetic flow meters converters uses SMT, so for user, it is unable to service, and cannot open the shell of converter.

Intelligent converters have self-diagnose function. Without trouble of power and hardware circuit, the normal trouble can be alarmed correctly. This information displays  on the left of LCD. The trouble is like this:

FQH ---- Flow high limit alarm; FQL----Flow low limit alarm;

FGP ---- Flow empty pipe alarm; SYS----System exciting alarm.

UPPER ALARM Flow high limit alarm; LOWER ALARM Flow empty pipe alarm;

LIQUID ALARM Flow empty pipe alarm; SYSTEM ALARM;System exciting alarm.

Troubleshooting**No display:**

- Check the power supply connection;
- Check the power fuse to see for OK;
- Check the contrast of LCD and regulate it to working state;

Exciting alarm

- Check if the exciting cables EX1 and EX2 did not connected;
- Check if the total resistance of sensor's exciting coil resistances less than 150Ω;
- If a) and b) are OK, the converter is failed.

Empty pipe alarm

- *If measured fluid full of testing pipe of sensor;
- *When shorting circuit three connectors SIG 1, SIG 2, SGND of converter, and no “Empty Alarm” displayed then the converter works OK. In this case, it is possible that conductivity of measured fluid may be small or empty threshold of empty pipe and range of empty pipe are set wrongly.
- *Check if the signal cable is OK;
- *Check if the electro-poles are OK or not.

Let the flow is zero, then the displayed conductivity should be less than 100%. Resistances of SIG1 to SGND and SIG2 to SGND are all less than 50kΩ (conductivity of water) during measurement operation. (It is better to test the resistances by means of multimeter with pointer to see the charging process well.)
 *The DC voltage should be less than 1V between DS1 and DS2 testing the voltage by means of multimeter. If DC voltage is larger than 1V, the electro poles of sensor were polluted that have to be cleaned.

Measure flow disallow

- *If measured fluid full of testing pipe of sensor;
- *Check if the signal cable is OK;
- *Check the sensor modulus and sensor zero whether set as the sensor escutcheon or leave factory checkout.

Encasement and reserve

Encasement

Electromagnetic flow meter converter is packed as vacuum, and can insulate wet. The bag it's appropriate one, if the bag is open, it will not product of original factory. Installation Manual, Certificate of Product and Packing List are all with the converter.

Shipping and storage

- To prevent the product from damage during shipping, keep the original package of manufacturer. The products should be stored in storehouse that meets following conditions:
- 6.5 Keep off raining and moisture;
 - 6.6 Keep off heavy vibration, and strike;
 - 6.7 Ambient temperature -20~+60 ℃;
 - 6.8 Humidity less than 80%.

Encasement and reserve

Afford three exciting frequency types: 1/16 frequency (type 1), 1/20 frequency (type 2), 1/25 frequency (type 3). The small-bore one should use 1/16 frequency, and large-bore one should use 1/20 or 1/25 frequency. When using, please select type 1 first, if the zero of velocity is too high, select the type 2 or type 3.

In the user's sensor that gives, often the sensor is not fit for the converters, at this time can do like this:

(1) Small exciting loop resist If the exciting loop resist is smaller than the sensor's request, can series resist to get the total value.

The series resist's power should be more than one time of fact, for example, series 10Ω on 250mA current, the power will be 3W.

(2) Large exciting loop resist (change exciting current) If the exciting loop resist is larger than the sensor's request, can change the exciting current, for example, if exciting loop resist is 70Ω, for 250mA this is larger, so can change the current to 187mA.

(3) Large exciting loop resist (change loop connect) If the exciting loop resist is larger than the sensor's request, can change the connect of loop, for example, if exciting loop resist is 200Ω, every exciting loop resist is 100Ω, parallel connection the upper and lower loop is OK.

According the analysis, change the connect of exciting loop, measure from either head of exciting loop, Total resist = (R1 + RL1) parallel connection (R2 + RL2) ≤ 120Ω;

(As the Fig. R1, R2----addition resists; RL1, RL2 exciting resists)

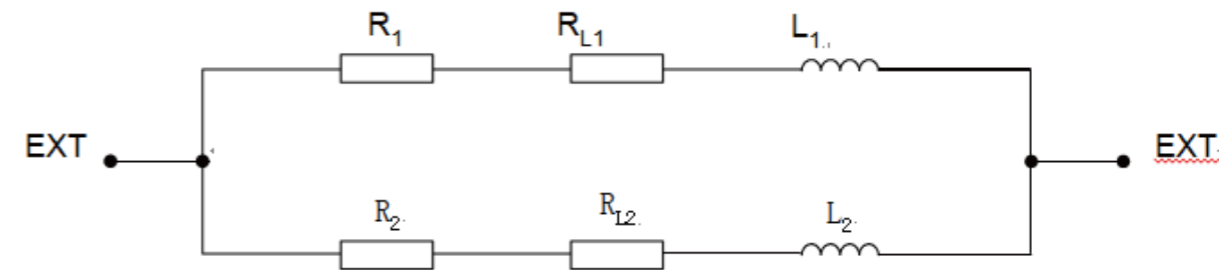

Total resist = (R1 + RL1) parallel connection (R2 + RL2) ≤ 120Ω; (As the Fig. R1, R2 addition resists; RL1, RL2 exciting resists)

(4) Sensor exciting current steady time so long (inductance is too large)For this question, firstly changing exciting type, select 1/16 or 1/25 frequency. If cannot content, change connect of exciting loop.

Exciting current transition time $\tau = L / R$

L ---- Exciting loop inductance; R exciting loop resist.

So decrease L and increase R both can decrease τ .

According the analysis, change the connect of exciting loop, measure from either head of exciting loop,

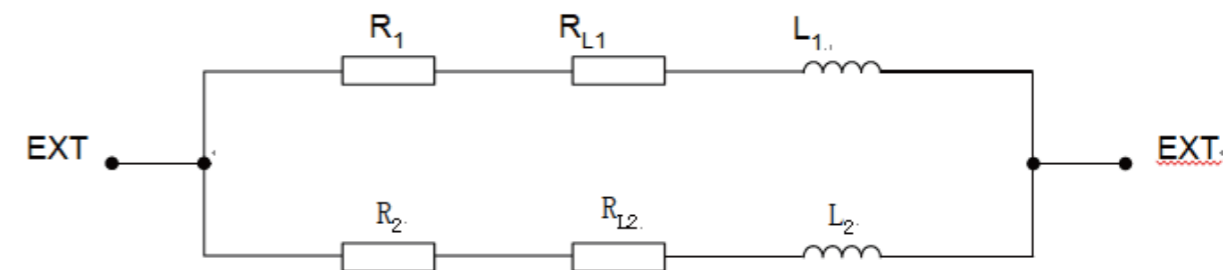

Total resist = (R1 + RL1) parallel connection (R2 + RL2) ≤ 120Ω;
 (As the Fig. R1, R2----addition resists; RL1, RL2 exciting resists)

Appendix Two: ON/OFF Switch Diagram

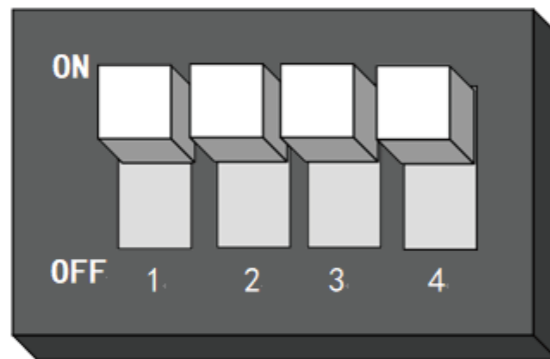

Key 1: ON: Supply up power (24V) for ALML output.

OFF: No connection.

Key 2: ON: Pulse output to OC gate when flow verification was taken. Connect pull-up resistor.

OFF: No connection.

Key 3: ON: Supply up power (24V) for ALMH output.

OFF: No connection.

Key 4: ON: Connected to RS485 terminal resistor for communication

OFF: No connection.

Note: Terminal used for far communication only.

Appendix Three: Analog Loop Communication function explanation

•Analog Loop Communication Bus network .

Analog Loop Communication Bus transfers data-signal through signal line which value is from 4 to 20mA. Therefore, it can save local data communication line and implement data communication. Its adaptive for local using.

The local network fig composed by Analog Loop Communication Bus is as follows:

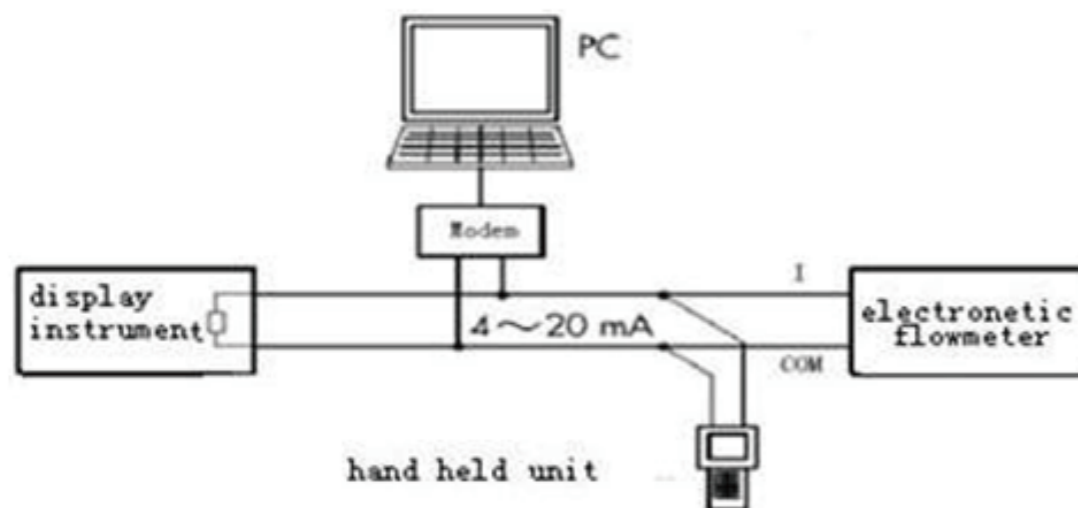

Instruction for setting of the converter

- 1.If you use the handset of our company, you need to set the meter address to 1 and set the baud rate to 4800;
- 2.If you use other handset such as 375 or 275, you need to set the meter address to 2 and set the baud rate to 4800; (This function is according to the real object please)
- 3.If the communication mode, the address or the baud rate of the meter is not set correctly, the handset can't set the parameters.

Matters need attention of Analog Loop Communication using function meter

- 1.Load which is parallel connection between electrical flow meter and Hand held unit and Analog Loop Communication MODEM is on polarity.
- 2.Resistance of circuit should be greater than 200Ω, less than 500Ω.
- 3.Hand held unit and Analog Loop Communication MODEM shouldn't be connection in series in current circuit. Set the baud rate to 4800;

Appendix four: Lightning protection notes.

When installing, users must connect the converter's ground terminal with the shell, and then ground them reliably, because the electrical current can be put into the earth through the shell by the gas discharger of lightning protection. If the shell has not been ground reliably, once lightning, it may cause a personal accident when there is somebody operating the converter. The specific details, you can see the connection diagram.

